

**LANTEC**

**LH Series Hoists**

OPTIONS & ACCESSORIES

## **Drum Brake**



---

**LANTEC**

Winch & Gear Inc.

GEAR DRIVES  
WINCHES & HOISTS  
BRAKES & CLUTCHES

***Driven to Excellence***

**Drum Brake**

The LANTEC LH Series Hoists are a complete, modular line of hoists with more than 10 basic models. With many flexible options, the LH Series Hoist is suitable for a wide variety of applications. LH Series Hoists are available with single drives and dual drives for higher horsepower capability.

# Details

Dimensions

Hoist Model	Mounting Offset	
	A	B
<i>All dimensions are in inches</i>		
LHS100	11.63	17.50
LHS110	11.81	17.50
LHS160	11.31	17.50
LHS170	11.63	17.50
LHS240	11.63	24.00
LHS330	11.63	24.00
LHS430	11.63	24.00

LANTEC's optional Drum Brake for LHS Series Hoists offers an additional level of safety for hoisting operations.

Acting directly on the hoist drum, this wet, multi-disc brake is designed to stop and hold the load in the unlikely event of power train failure. The Drum Brake is intended specifically as an emergency brake. Normal braking (dynamic and holding) is done through the brake valve and motor brake.

The Drum Brake mounts to the end of the hoist, opposite the motor.

# Features

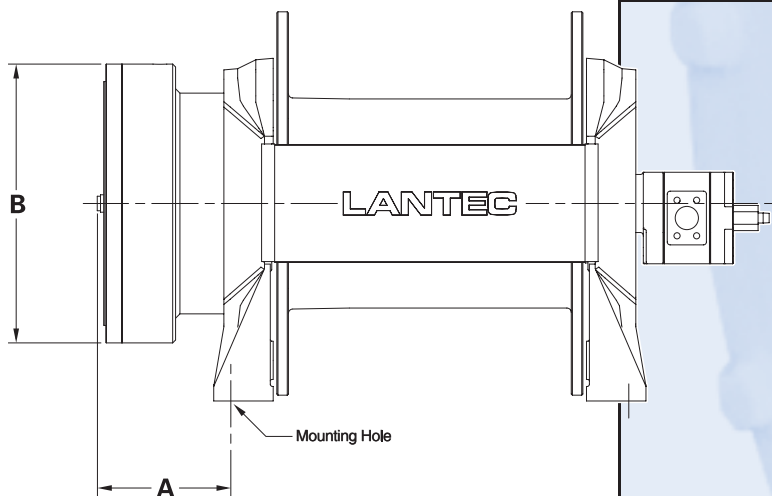

**Designed for emergency load stopping and holding**

**Acts directly on the hoist drum, independent from motor, sprag clutch, motor brake and planetary gears**

**Wet, multi-disc design is completely enclosed, running in lubricating oil, unaffected by the environment and corrosion resistant**

**Spring applied and hydraulic pressure released for positive engagement**

**Isolated from system back pressure to ensure full brake capacity at all times**

**No adjustments necessary, reducing your maintenance costs**

**Models available for all LHS Series Hoists**

LANTEC Winch & Gear is a part of TWG, a global leader in standard and engineered winch, gearbox and load information systems.



**LANTEC**  
Winch & Gear Inc.

5827 Production Way  
Langley, BC V3A 4N5  
Canada

Tel (604) 530-0737  
Fax (604) 530-2889

sales@lantecgear.com  
www.lantecgear.com

PROUDLY DISTRIBUTED BY