

LANTEC

LH Series Hoists

OPTIONS & ACCESSORIES

Drum Brake



LANTEC

Winch & Gear Inc.

GEAR DRIVES
WINCHES & HOISTS
BRAKES & CLUTCHES

Driven to Excellence

Drum Brake

The LANTEC LH Series Hoists are a complete, modular line of hoists with more than 10 basic models. With many flexible options, the LH Series Hoist is suitable for a wide variety of applications. LH Series Hoists are available with single drives and dual drives for higher horsepower capability.

Details

Dimensions

Hoist Model	Mounting Offset	
	A	B
<i>All dimensions are in inches</i>		
LHS100	11.63	17.50
LHS110	11.81	17.50
LHS160	11.31	17.50
LHS170	11.63	17.50
LHS240	11.63	24.00
LHS330	11.63	24.00
LHS430	11.63	24.00

LANTEC's optional Drum Brake for LHS Series Hoists offers an additional level of safety for hoisting operations.

Acting directly on the hoist drum, this wet, multi-disc brake is designed to stop and hold the load in the unlikely event of power train failure. The Drum Brake is intended specifically as an emergency brake. Normal braking (dynamic and holding) is done through the brake valve and motor brake.

The Drum Brake mounts to the end of the hoist, opposite the motor.

Features

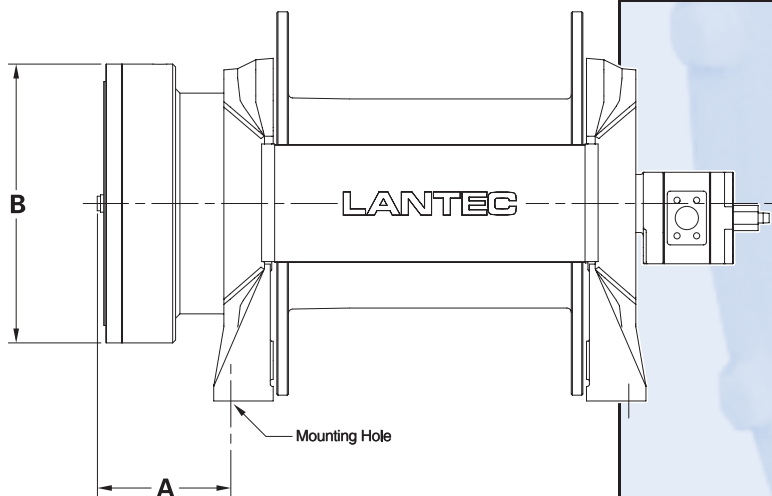

Designed for emergency load stopping and holding

Acts directly on the hoist drum, independent from motor, sprag clutch, motor brake and planetary gears

Wet, multi-disc design is completely enclosed, running in lubricating oil, unaffected by the environment and corrosion resistant

Spring applied and hydraulic pressure released for positive engagement

Isolated from system back pressure to ensure full brake capacity at all times

No adjustments necessary, reducing your maintenance costs

Models available for all LHS Series Hoists

LANTEC Winch & Gear is a part of TWG, a global leader in standard and engineered winch, gearbox and load information systems.

PROUDLY DISTRIBUTED BY