

INSTRUCTION AND PARTS MANUAL  
**MODEL M30**  
PLANETARY HYDRAULIC WINCH



**THE LOGICAL CHOICE**

	<p><b>READ THIS MANUAL BEFORE INSTALLING, OPERATING OR SERVICING THIS PRODUCT. THIS MANUAL CONTAINS IMPORTANT INFORMATION. MAKE THIS MANUAL AVAILABLE TO ALL PERSONS RESPONSIBLE FOR THE OPERATION, INSTALLATION, SERVICING AND MAINTENANCE OF THIS PRODUCT.</b></p>
---	--

# PULLMASTER LIMITED WARRANTY

Effective 1/1/2002

*SUPERSEDES ALL PRIOR WARRANTIES*

Seller warrants that each article sold under this order shall at the time of shipment (i) conform to applicable specifications, and (ii) be free from defects in material and workmanship during normal and ordinary use and service (the "Warranty").

Buyer's exclusive remedy and Seller's sole obligation under this Warranty shall be, at Seller's option, to repair or replace any article or part thereof which has proven to be defective, or to refund the purchase price of such article or part thereof.

This Warranty shall expire one (1) year from the date the article is first shipped by Seller. Notice of claimed breach of this Warranty must be given by Buyer to Seller within the applicable period. Such notice shall include an explanation of the claimed warranty defect and proof of date of purchase of the article or part thereof for which warranty coverage is sought. No allowances shall be made by Seller for any transportation, labor charges, parts, "in and out" costs, adjustments or repairs, or any other work, unless such items are authorized in writing and in advance by Seller. Nor shall Seller have any obligation to repair or replace items which by their nature are expendable.

If an article is claimed to be defective in material or workmanship, or not to conform to the applicable specifications, Seller will either examine the article at Seller's site or issue shipping instructions for return to Seller. This Warranty shall not extend to any articles or parts thereof which have been installed, used, or serviced otherwise than in conformity with Seller's applicable specifications, manuals, bulletins, or instructions, or which shall have been subjected to improper installation, operation, or usage, misapplication, neglect, overloading, or employment for other than normal and ordinary use and service.

This Warranty shall not apply to any articles or parts thereof furnished by Seller to Buyer's specifications and/or furnished by Buyer or acquired from others at Buyer's request.

SELLER MAKES NO EXPRESS WARRANTIES AND NO IMPLIED WARRANTIES OF ANY KIND, OTHER THAN THE WARRANTY EXPRESSLY SET FORTH ABOVE. SUCH WARRANTY IS EXCLUSIVE AND IS MADE AND ACCEPTED IN LIEU OF ANY AND ALL OTHER WARRANTIES, EXPRESS OR IMPLIED, INCLUDING WITHOUT LIMITATION THE IMPLIED WARRANTIES OF MERCHANTABILITY AND FITNESS FOR A PARTICULAR PURPOSE.

The remedies for this Warranty shall be only those expressly set forth above, to the exclusion of any and all other remedies of whatsoever kind. The limited remedies set forth above shall be deemed exclusive, even though they may fail their essential purpose. No agreement varying or extending the foregoing Warranty, remedies, exclusions, or limitations shall be effective unless in a writing signed by an executive officer of Seller and Buyer. This Warranty is non-transferable.

Under no circumstances shall Seller be liable (i) for any damage or loss to any property other than the warranted article or part thereof, or (ii) for any special, indirect, incidental, or consequential damage or loss, even though such expenses, damages, or losses may be foreseeable.

The foregoing limitations on Seller's liability in the event of breach of warranty shall also be the absolute limit of Seller's liability in the event of Seller's negligence in manufacture, installation, or otherwise, with regard to the articles covered by this Warranty, and at the expiration of the Warranty period as above stated, all such liabilities shall terminate.



## WARNING

**PULLMASTER** planetary winches/drives are not designed for operations involving lifting or moving personnel. The **PULLMASTER WINCH CORPORATION** cannot be held liable or responsible for any accident resulting from such use of **PULLMASTER** planetary winches/drives.

**Note:** Specifications contained in this Instruction and Parts Manual are subject to change without notice.

# SAFETY RECOMMENDATIONS



**DANGER**

**FAILURE TO COMPLY WITH THE FOLLOWING SAFETY RECOMMENDATIONS AND LOCAL RULES AND REGULATIONS WILL RESULT IN PROPERTY DAMAGE, SEVERE INJURY OR DEATH.**



Definition: **Caution** indicates a potentially hazardous situation which, if not avoided may result in minor or moderate injury.



Definition: **Warning** indicates a potentially hazardous situation which, if not avoided could result in death or serious injury.



Definition: **Danger** indicates a potentially hazardous situation which, if not avoided will result in death or serious injury.

The planetary hydraulic winches are made for hoisting and lowering loads and to be operated by trained and professional personnel. They are not designed for operations involving lifting or moving personnel. The winches are powered by hydraulic power. The ropes / cables for hoisting operations are not supplied by PULLMASTER. The winches are always assembled in an application, they do not function as an independent machine and it is not allowed to use them as such.

The winches are to be used within the specifications as listed in the manual under "SPECIFICATIONS". Other use as foreseen in the functional description of the hydraulic winch is not allowed without written permission from PULLMASTER.

1. Do not install, operate or service winch before reading and understanding manufacturer's instructions.
2. The winch described herein is not designed for operations involving lifting or moving personnel.
3. Do not lift or carry loads over people.
4. Do not exceed recommended operating pressure (psi) and operating volume (gpm).
5. Do not jerk the winch. Always smoothly accelerate and decelerate load.
6. Do not operate a damaged, noisy or malfunctioning winch.
7. Do not leave a load suspended for any extended period of time.
8. Never leave a suspended load unattended.
9. Winch should be maintained and operated by qualified personnel.
10. Inspect winch, rigging, mounting bolts and hoses before each shift.
11. Warm-up equipment before operating winch, particularly at low ambient temperatures.
12. Verify winch function by raising and lowering a full test load to a safe height before each shift.
13. Do not weld any part of the winch.
14. Verify gear lubrication and brake circulation supply and return before operating winch.
15. Be sure of equipment stability before operating winch.
16. Wear proper clothing to avoid entanglement in rotating machinery.
17. Always stand clear of the load.
18. Use only recommended hydraulic oil and gear lubricant.
19. Keep hydraulic system clean and free from contamination at all times.
20. Maintain winch and equipment in good operating condition. Perform scheduled maintenance regularly.
21. Keep hands clear when winding wire rope onto the winch drum.
22. Do not use the wire rope as a ground for welding.
23. Rig the winch carefully. Ensure that the wire rope is properly anchored to the correct cable anchor slot at the cable drum.
24. Do not lift a load with a twisted, kinked or damaged wire rope.
25. Consult wire rope manufacturer for size, type and maintenance of wire rope.
26. Maintain three wraps of wire rope on the cable drum at all times.
27. In case of a power failure or breakdown leading to an unexpected stop of the hydraulic power circuit, stand clear of the area and the load being hoisted, take the necessary precautions to prevent access to area where the load is halted.
28. The noise level of the winch is 89 dBA measured on a distance of 1.00 meter, 1.60 meters high. The measuring equipment used was: Realistic #42-3019.
29. Clean up any oil spillage immediately.
30. Wear proper clothing and personal protection equipment such as, footwear, safety goggles and a hard hat. Read manual first.



# DESCRIPTION OF THE MODEL M30

## GENERAL DESCRIPTION:

The PULLMASTER Model M30 is a planetary hydraulic winch having equal speed in both directions. The main components of this unit are:

- + hydraulic gear motor
- + multi disc brake with static and dynamic function
- + primary planet reduction
- + secondary planet reduction
- + final planet reduction
- + brake housing
- + cable drum
- + final drive housing

## FUNCTION IN FORWARD ROTATION (HOISTING):

In forward rotation, or when the winch is pressurized for hoisting, the output torque and rpm of the hydraulic motor are transmitted to the sun gear of the primary planet reduction. The output torque and rpm of the primary reduction stage are transmitted to the secondary reduction stage by the secondary sun gear, which is splined to the primary planet hub. In forward rotation, or when a load is raised, an over-running clutch, which connects the motor drive shaft to the automatic brake assembly, permits free rotation of the sun gear, without effecting the brake. When the winch rotation is stopped, the load on the cable drum causes the over-running clutch to lock and the maximum load is held safely by the disc brake.

## FUNCTION IN REVERSE ROTATION (LOWERING):

In reverse rotation, or when the winch is pressurized for lowering of a load, hydraulic pressure from the reverse side of the hydraulic motor is channelled to the brake piston, causing the brake piston to release the multi-disc brake against a number of brake springs. The over-running clutch, connecting the motor drive shaft to the brake assembly, locks, causing the brake disks to rotate between divider plates, which are engaged into the brake housing. If the load on the cable drum tends to effect the lowering speed, the resulting pressure drop in the brake piston causes friction between the brake discs and the divider plates. In this way a completely smooth lowering speed can be achieved in a stepless operation by modulation of the winch control handle. When the control handle is returned to neutral position, rotation stops and the disc brake applies automatically.

During lowering operations of the winch, the friction created by the brake discs results in temperature. This temperature is dissipated by the circulation of hydraulic fluid through the brake housing, supplied internally from the motor or externally depending on the brake code of the winch. For efficient cooling of the automatic brake, models with external circulation should be adjusted to supply 5 (US) gpm (19 l/min). Models with internal circulation have been set at the factory for correct circulation flow. This flow must be returned directly to the reservoir with a permissible back pressure of 30 psi (2 bar).

## IMPORTANT:

Under no circumstances must the pressure in the brake housing be permitted to exceed 30 psi (2 bar). Excessive pressure in the brake housing will damage the oil seal separating the brake housing from the drum interior. Damage to this seal will cause the drum to fill up with hydraulic fluid. In order to prevent damage to the drum seal and end cover of the final drive housing, when the cable drum fills up with hydraulic fluid, a breather relief ( see PARTS REFERENCE, item 130) is installed on the end cover. The breather relief bleeds to atmosphere and serves as a warning that the seal between brake housing and drum has been damaged.

# EXPLANATION OF MODEL CODING

**M 30 X - XX - XX - XX X - X XXXX**

**BASIC UNIT SERIES**

M = Equal speed in both directions

**SIZE OF UNIT**

**REDUCTION RATIO**

Only used for non standard reduction ratios  
(For other ratios refer to appendix)

**TYPE OF BRAKE**

- 0 Winch without brake
- 3 Automatic brake, clockwise drum rotation, internal circulation flow
- 4 Automatic brake, external brake release, clockwise drum rotation, internal circulation flow
- 5 Automatic brake, external brake release, counterclockwise drum rotation, internal circulation flow
- 6 Automatic brake, counterclockwise drum rotation, internal circulation flow
- 7 Automatic brake, clockwise drum rotation, external circulation flow
- 8 Automatic brake, external brake release, clockwise drum rotation, external circulation flow
- 9 Automatic brake, external brake release, counterclockwise drum rotation, external circulation flow
- 10 Automatic brake, counterclockwise drum rotation, external circulation flow
- 11 Brake effective in both directions, external circulation flow
- 17 Brake effective in both directions, external circulation flow, external drain, external brake release

**HYDRAULIC MOTOR**

- 86 Hydraulic motor, 3 inch gear section (12.3 cubic inch displacement)  
(Other gear sections for this motor are optional)

**DRUM SIZE**

- 1 10.0 inch drum diameter X 17.0 inch flange diameter X 11.0 inch length - STANDARD  
(For other drum sizes refer to APPENDIX A)

**OPTIONS**

**DESIGN REVISION**

**SPECIFICATION NUMBER**

Describes features not identified by preceding codes

**NOTE:** Clockwise and counterclockwise drum rotation is the direction of rotation for pulling or hoisting, established by looking at the hydraulic motor.

# OPTIONS

## COUNTERCLOCKWISE ROTATION:

The drum rotation of the standard PULLMASTER Model M30 planetary winch is clockwise for hoisting when looking at the hydraulic motor of the winch. Drum rotation for counterclockwise hoisting direction is available as an option.

## INTERNAL CIRCULATION:

The PULLMASTER Model M30 planetary winch has an external circulation flow supply line to cool the brake. Internal circulation is available as an option.

## EXTERNAL BRAKE RELEASE:

PULLMASTER planetary winches can be supplied with an **external brake release** which permits release of the automatic disc brake from an external pressure source.



**FAILURE TO PROPERLY VENT EXTERNAL BRAKE RELEASE PORT WILL TRAP BRAKE PRESSURE AND ALLOW THE LOAD TO DROP, CAUSING PROPERTY DAMAGE, SEVERE INJURY OR DEATH. WINCHES SUPPLIED WITH EXTERNAL RELEASE OPTION MUST BE CONNECTED ACCORDING TO "TYPICAL HYDRAULIC CIRCUIT".**

## CABLE DRUM SIZES:

Aside from the standard drum sizes listed in APPENDIX A, the PULLMASTER Model M30 planetary winch can be supplied with optional drums to accommodate large wire rope storage capacity.

## DRUM GROOVING:

Cable drums for the PULLMASTER Model M30 planetary winch can be grooved. Where this option is a requirement, it is necessary to state the size of wire rope which is to be used with the winch.

## OPTIONAL GEAR SECTION FOR THE HYDRAULIC MOTOR:

The performance of the standard PULLMASTER Model M30 planetary winch may be changed by using a different displacement motor. (Contact the factory for performance information.)

## HYDRAULIC MOTORS FOR HIGH PRESSURE HYDRAULIC SYSTEMS:

The operating pressure of the PULLMASTER Model M30 planetary winch is limited to 2500 psi (172 bar). For hydraulic systems operating with a higher range of hydraulic pressure, the winch can be supplied with a hydraulic piston motor, which will provide for the same basic performance in terms of line pull and line speed capacity. (Contact the factory for this requirement.)

## FREESPOOLING:

This option permits wire rope being pulled off the cable drum by an operator. **Freespooling** should not be confused with **free fall**. The **freespool** coupling cannot be disengaged or re-engaged with a load on the wire rope or while the cable drum is turning.

## FREE FALL:

This option is available in an **emergency** or **controlled free fall** version. The **emergency free fall** allows a full release of the maximum load. The **controlled free fall** allows up to 30% of the maximum load to be lowered fast and stopped safely.

The PULLMASTER WINCH CORPORATION will consider other options for quantity requirements.

# SPECIFICATIONS

Performance specifications are based on standard hydraulic motor, gear ratio and cable drum with 7/8 inch diameter wire rope. For other cable drums refer to APPENDIX A. For other reductions or motors, refer to supplement inside back cover. Performance specifications for winches supplied with optional motors are provided in attached supplement.

## CABLE DRUM DIMENSIONS (STANDARD DRUM):

Barrel diameter	10.00 in	254 mm
Flange diameter	17.00 in	432 mm
Barrel length	11.00 in	279 mm

## CABLE STORAGE CAPACITY:

<b>(Size of wire rope)</b>	7/16 in	612 ft	186 m
	1/2 in	413 ft	126 m
	9/16 in	383 ft	117 m
	5/8 in	297 ft	90 m
	3/4 in	210 ft	64 m
	7/8 in	140 ft	43 m
	1 in	91 ft	28 m

**MAXIMUM OPERATING PRESSURE:** 2500 psi 172 bar

**MAXIMUM OPERATING VOLUME:** 115 (US) gpm 435 l/min

**MINIMUM OPERATING VOLUME:** 30 (US) gpm 114 l/min

**DRUM TORQUE AT MAXIMUM PRESSURE:** 135,937 lb-in 15,359 Nm

**DRUM RPM AT MAXIMUM VOLUME:** 49 rpm

## MAXIMUM LINE PULL AT MAXIMUM PRESSURE:

Bare drum	25,000 lb	111.2 kN
Full drum	16,860 lb	75.0 kN

## MAXIMUM LINE SPEED AT MAXIMUM VOLUME:

Bare drum	140 fpm	43 m/min
Full drum	207 fpm	63 m/min

## PERMISSIBLE SYSTEM BACK PRESSURE AT MOTOR RETURN PORT:

65 psi 4.5 bar

## PERMISSIBLE PRESSURE AT CIRCULATION SUPPLY PORT:

30 psi 2 bar

**LUBRICATING OIL:** Refer to RECOMMENDATIONS for viscosity and instructions.  
Refer to APPENDIX A for oil volume required.

# PERFORMANCE GRAPHS

PG-M30-B

## LINE PULL VS. OIL PRESSURE

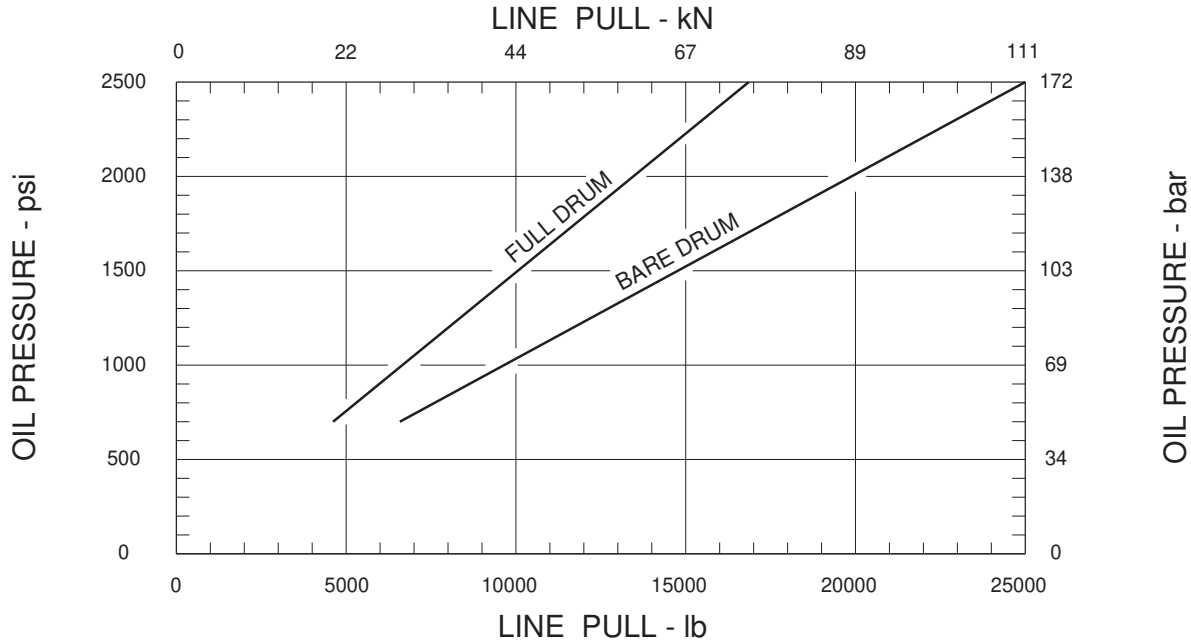

## LINE SPEED VS. OIL VOLUME

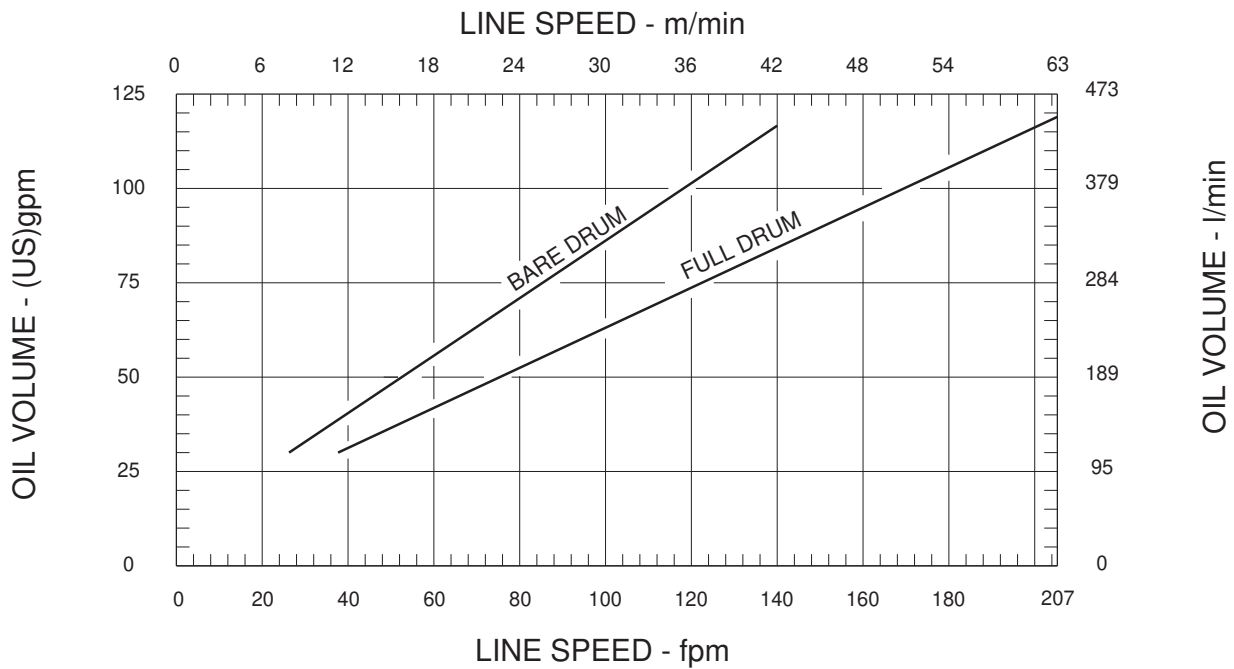

Performance graphs are based on standard hydraulic motor, gear ratio and cable drum with 7/8 inch diameter wire rope.



# TYPICAL HYDRAULIC CIRCUIT

HC-M30,H30

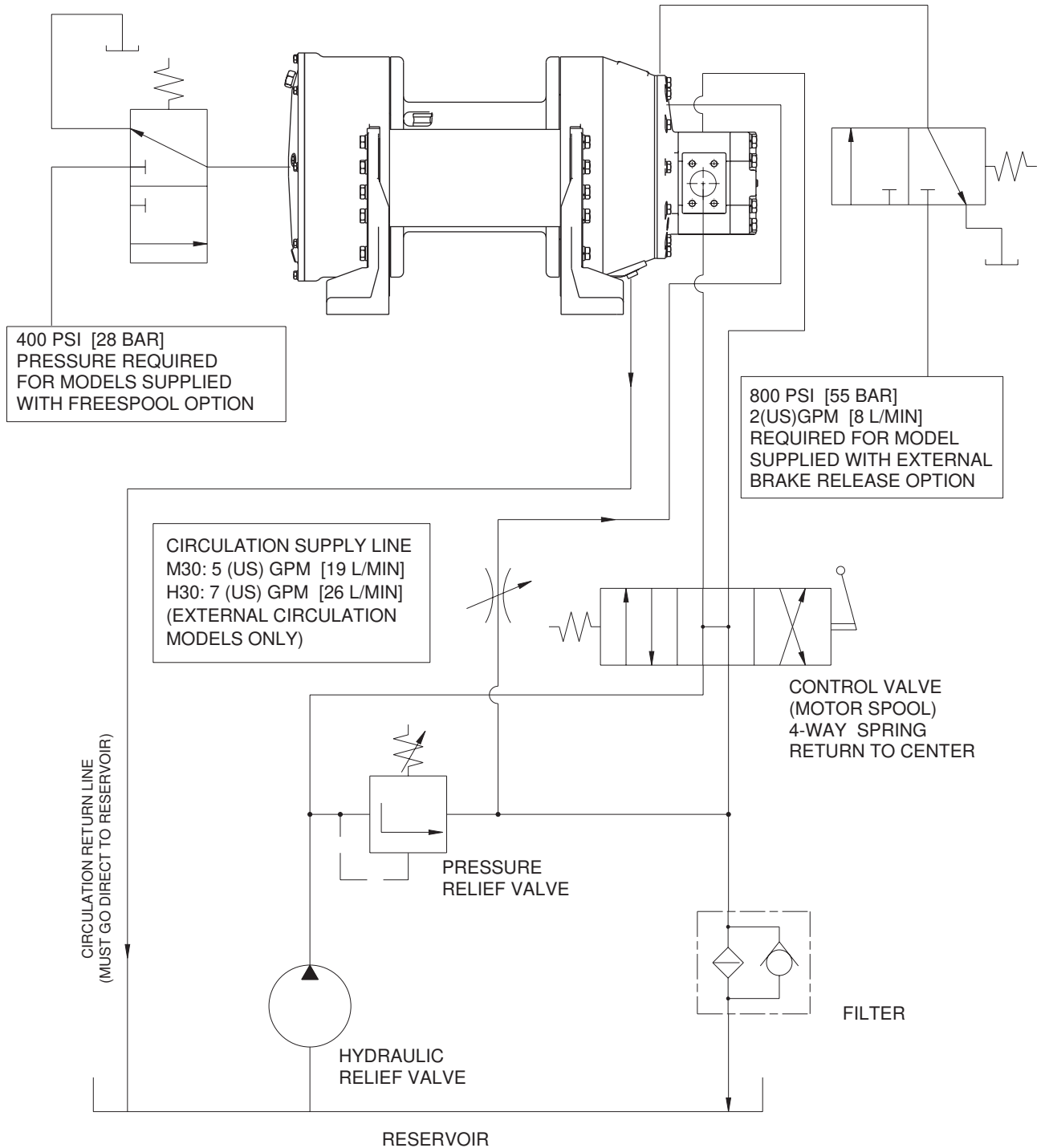

# RECOMMENDATIONS

## HYDRAULIC FLUID:

The hydraulic fluid selected for use with PULLMASTER planetary winches should be a high grade, petroleum based fluid, with rust, oxidation and wear resistance. Fluid cleanliness and operating viscosity are critical to winch reliability, efficiency and service life.

For optimum performance, the recommended viscosity range at operating temperature is 81 - 167 SUS (16 - 36 CS). For extreme operating conditions of short duration, the maximum viscosity range of 58 - 4635 SUS (10 - 1000 CS) should not be exceeded.

For optimum performance, the winch recommended hydraulic fluid temperature operating range is 80 - 150F (27 - 66 C). For extreme operating conditions of short duration, the maximum temperature range of -5 - 180F (-21 - 82 C) should not be exceeded.

## LUBRICATION:

The winch gear train requires oil bath lubrication. The winch is shipped from the factory without lubricating oil.

**IMPORTANT:** ADD LUBRICATING OIL BEFORE RUNNING WINCH.

Refer to INSTALLATION DRAWING for location of lubricating oil fill port. Refer to APPENDIX A for quantity of oil required. For normal operating temperatures use SAE 90 lubricating oil. Consult lubricating oil supplier or factory for temperature beyond normal operating range.

## HYDRAULIC PUMP:

For maximum performance of the PULLMASTER planetary winch, the hydraulic pump must supply the maximum flow of hydraulic fluid at the hydraulic pressure stated in SPECIFICATIONS.

## HYDRAULIC CONTROL VALVE:

The standard control valve used for operation of the PULLMASTER planetary winch must have a four-way, spring return to neutral feature, which provides for open flow from the pressure ports of the winch to the reservoir in neutral position of the control (motor spool). It is important to point out that good speed control, especially when lowering a load, depends on the "metering" characteristics of the control valve. The better the oil flow is "metered" the better will be the speed control.

## HYDRAULIC PRESSURE RELIEF:

The hydraulic circuit for the PULLMASTER planetary winch requires a pressure relief set at the operating pressure (see SPECIFICATIONS). Usually, a pressure relief is part of the hydraulic control valve. Where this is not the case, a separate pressure relief valve must be installed and set at the recommended maximum pressure.

## HYDRAULIC RESERVOIR:

It is recommended that the hydraulic reservoir has sufficient capacity to provide good heat dissipation in order to prevent over-heating of the hydraulic fluid. The hydraulic reservoir should be made from clean and scale-free material to prevent contamination of the hydraulic fluid. In order to prevent air from being mixed with the hydraulic fluid, the reservoir should have an over-flow baffle separating the return lines from the suction line and all return lines should enter the reservoir below the fluid level. The reservoir should be mounted close to and above the hydraulic pump in a location which provides for free air circulation around the reservoir.

## HYDRAULIC HOSES:

The following hydraulic hoses are recommended for maximum efficiency of the PULLMASTER Model M30 planetary winch:

Pressure lines:	Equivalent to SAE 100R12-32
Circulation return line:	Equivalent to SAE 100R4-16
Circulation supply line:	Equivalent to SAE 100R6-6*

\* Only for models with external circulation

It is recommended that a larger size of hydraulic hose is installed where the pressure lines or the circulation lines are excessively long.

## HYDRAULIC FILTER:

Hydraulic filter recommendations for the hydraulic circuit of the PULLMASTER planetary winch, based on a return line filter, are given as follows:

Average Atmosphere:	10 microns
Dusty Atmosphere:	5 microns

In order to prevent accidental stoppage of the return line flow, the oil filter should have a by-pass feature.

## USE OF AN E STOP:

### **(FOR EUROPEAN MACHINERY DIRECTIVE APPLICATIONS)**

The use of an E stop (emergency) is mandatory in the controls circuit. The E stop is to be placed in the operator's control panel. The E stop must be designed and placed in line with EN 60204 and EN 418.

# INSTALLATION INSTRUCTIONS



**DANGER**

**FAILURE TO FOLLOW INSTALLATION INSTRUCTIONS WILL  
RESULT IN PROPERTY DAMAGE, SEVERE INJURY OR DEATH.**

The initial installation or mounting of a PULLMASTER planetary winch is critically important for proper operation and performance. If the winch is mounted to an uneven surface, the centre line of the unit can be distorted to a point where the winch will not operate in either direction. It is therefore very important that the following instructions are observed when a PULLMASTER planetary winch is installed:

- 1) Make certain that the mounting platform is sufficiently strong in order to avoid deflection when a load is lifted.
- 2) Set the winch on the mounting platform and check Gap "A", "B", "C" and "D".

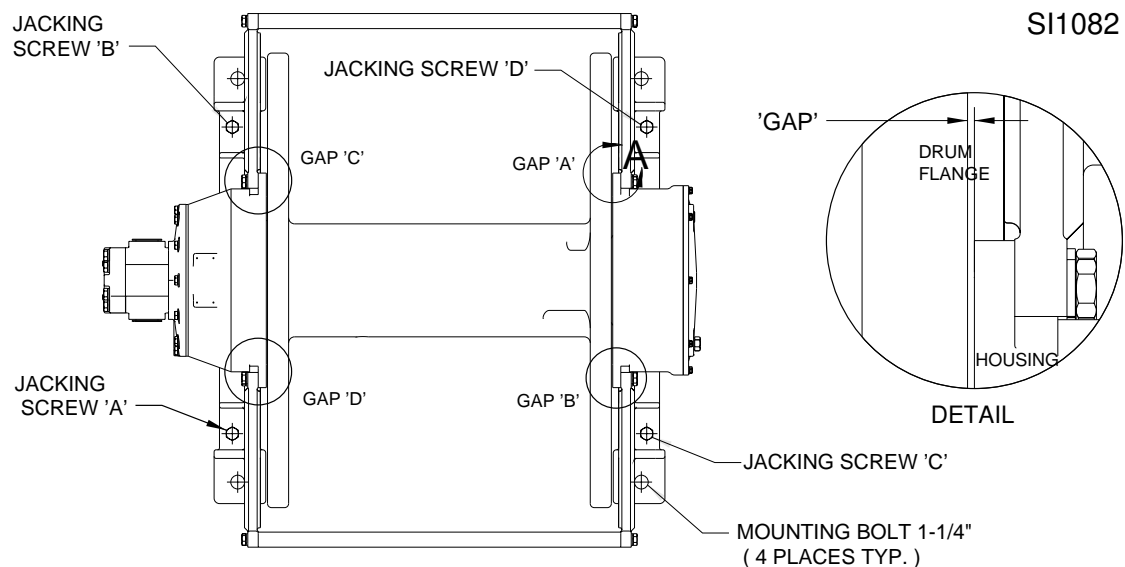

- 3) If Gap "A" is within .007" to Gap "B" and Gap "C" is within .007" to Gap "D", proceed to step 5. If Gaps are outside this limit, proceed to step 4.

Note: Difference between Gaps "A" and "B" and Gaps "C" and "D" may not be equal.

- 4) Gaps can be adjusted as required by adjusting Jacking Screw diagonally opposite to the Gap. Reduce a gap by turning Jacking Screw clockwise or increase a gap by turning Jack Screw counterclockwise.
  - a) To adjust Gap "A" adjust Jacking Screw "A".
  - b) To adjust Gap "B" adjust Jacking Screw "B".
  - c) To adjust Gap "C" adjust Jacking Screw "C".
  - d) To adjust Gap "D" adjust Jacking Screw "D".

# INSTALLATION INSTRUCTIONS

- 5) Measure the space underneath the four mounting pads with a feeler gauge and use shim stock of equivalent thickness in the space between the mounting pad and the mounting surface. Install mounting bolts (for bolt size and grade refer to INSTALLATION DIMENSIONS). Tighten mounting bolts per BOLT TORQUE CHART.
- 6) Fill the winch with lubricating oil. (See APPENDIX A for oil volume required.)
- 7) Use recommended circuit components and hydraulic hoses.
- 8) The circulation return line of the winch should be plumbed in such a manner that the brake housing remains full of oil at all times. Connect the return line directly to reservoir. Do not connect to a common return line.
- 9) Before operating the winch with a load, verify adequate circulation flow through the circulation return line as stated in TYPICAL HYDRAULIC CIRCUIT. Verify that pressure measured at the circulation supply port does not exceed the permissible pressure stated in SPECIFICATIONS. Winches equipped with the internal circulation option will supply circulation flow only when the winch is run in the lowering direction.
- 10) Verify that breather relief, item 130, is in place on end cover, item 120, above oil level. Rotate end cover if breather relief is below oil level.

**IMPORTANT:**

Do not replace breather relief with a pipe plug. The breather relief does not prevent oil seal failure but serves as an indicator or warning that the oil seals between brake housing and the cable drum interior have failed and must be replaced immediately. If these oil seals are changed, additional failure of the drum seal and potential damage to the end cover is prevented.

# OPERATING INSTRUCTIONS



**DANGER**

**FAILURE TO FOLLOW OPERATING INSTRUCTIONS WILL  
RESULT IN PROPERTY DAMAGE, SEVERE INJURY OR DEATH.**

After the PULLMASTER planetary winch has been installed in accordance with the INSTALLATION INSTRUCTIONS, the wire rope can be fastened to the cable drum.

**IMPORTANT:** The ropes, chains, slings, etc. are not part of the winch and are not covered by this manual. Refer to manufacturer's handling, inspection and maintenance recommendations to avoid potential accidents. For selection of ropes, etc. please check the following product standards: DIN 15020, prEN 818-1/9, prEN 1492-1/2, prEN 1677-1/3 and other relevant product standards.

- 1) The cable drum of the PULLMASTER planetary winch has two cable anchor slots, one for clockwise and one for counterclockwise hoisting. Standard rotation for hoisting is clockwise when looking at the hydraulic motor of the unit. It is critical to select the cable anchor slot which will permit winding of the wire rope on the drum in the correct direction of rotation. If the wire rope is wound on the cable drum in the wrong direction of rotation, the winch will have no braking capacity. Each winch is shipped from the factory with a label on the drum indicating the correct cable anchor slot.

## WIRE ROPE INSTALLATION

Clockwise hoisting winch shown.

(Use cable anchor slot on opposite side of drum for counterclockwise hoisting winch.)

Feed the wire rope through the cable anchor slot. Loop rope back into slot as shown. Insert cable anchor and pull rope tight to wedge rope in slot.

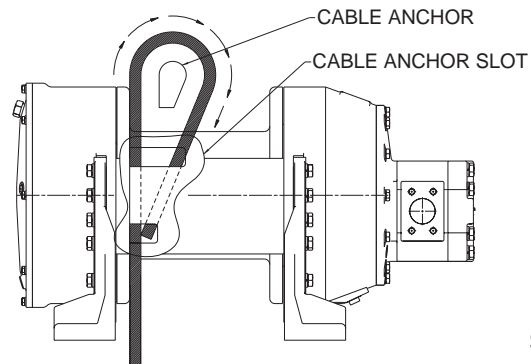

SI1013-30

- 2) On wire rope installation, care must be taken that the wire rope is wrapped completely around the cable anchor and properly pulled into the cable anchor slot in the cable drum. The cable drum requires 4 wraps of wire rope under tension for safety.
- 3) The winch operation is controlled by a single control valve lever which has a **forward**, a **reverse** and a **neutral** position. Speed control in either direction is obtained by modulation of the control valve lever. Maximum line speed in either direction is obtained when the control valve lever is moved as far as it can go. The disc brake of the winch will come on automatically when the winch control lever is returned to **neutral**.
- 4) Always warm up equipment prior to operating winch, particularly in low ambient temperature. Circulate hydraulic oil through the winch control valve for several minutes to warm the hydraulic system. To prime the winch with warm oil, operate the winch at slow speed, forward and reverse, several times.
- 5) Prevent corrosion damage to winch interior. If not used regularly, run winch up and down at least once every two weeks.
- 6) To ensure proper winch installation and function, raise and lower a full test load to a safe height before using winch for regular operation at the start of each shift.

If, after a new installation, the winch does not function properly, refer to the TROUBLESHOOTING section of this manual.

# TROUBLE SHOOTING

**GENERAL:**

In most cases, when the hydraulic winch does not perform satisfactorily, the cause of malfunction is found somewhere in the hydraulic circuit. Before the winch is removed from its mounting and disassembled, all of the hydraulic circuit components should be checked for proper function.

**IMPORTANT:**

**The hydraulic oil volume relates to the line speed or rpm of the winch.**

Therefore, if the winch does not produce the specified maximum rated line speed or drum rpm, a loss of hydraulic flow somewhere in the hydraulic circuit system can be analysed. If this condition exists, install a flow meter into the hydraulic circuit to check the volume supplied to the pressure port of the hydraulic winch motor when the winch control is completely opened. The flow meter should indicate the maximum operating volume. If this test indicates a loss of hydraulic flow, check the hydraulic pump, the relief valve and the control valve. If the pump is driven by V-belts, check for belt slippage.

**The hydraulic pressure relates to the line pull or lifting capacity of the winch.**

If the winch will not lift the specified maximum line pull, install a pressure gauge into the pressure line leading to the hoisting port on the hydraulic winch motor. Stall the winch to prevent rotation of the drum and then open the control valve. Check the hydraulic pressure reading of the installed pressure gauge. If the pressure reads below the specified maximum operating pressure, look for trouble in the hydraulic pump, the relief valve and the control valve. If the pump is driven by V-belts, check for belt slippage. When checking oil pressure and volume in the hydraulic circuit, make certain that the hydraulic reservoir is filled to the top level and the hydraulic pump is running at maximum operating rpm.

Only if the hydraulic system has been checked and found to be in order, use the following indications for probable causes of failure in the winch:

FAILURE	PROBABLE CAUSE
<p><b>Winch will not produce line pull at maximum pressure as listed in SPECIFICATIONS.</b></p>	<ul style="list-style-type: none"> <li>a) Winch is mounted to an uneven surface. (See INSTALLATION INSTRUCTIONS.)</li> <li>b) Cable sheaves or block purchase operated with the winch are not turning freely.</li> <li>c) Damage or wear in the hydraulic motor.</li> <li>d) Excessive back pressure in the hydraulic system.</li> <li>e) Relief valve may be set too low. (See SPECIFICATIONS for maximum operating pressure.)</li> </ul>
<p><b>Winch will not produce line speed at maximum volume as listed in SPECIFICATIONS.</b></p>	<ul style="list-style-type: none"> <li>a) Winch is mounted to an uneven surface. (See INSTALLATION INSTRUCTIONS.)</li> <li>b) Cable sheaves or block purchase operated with the winch are not turning freely.</li> <li>c) Damage or wear in the hydraulic motor.</li> <li>d) Excessive back pressure in the hydraulic circuit.</li> </ul>
<p><b>Winch will not reverse.</b></p>	<ul style="list-style-type: none"> <li>a) Leakage out of the brake piston prevents the brake from being released against the brake springs. This is caused by damaged O-ring seals on the brake piston.</li> <li>b) The O-ring seals, on the brake release channel between the motor adaptor and the brake housing is damaged. If this failure occurs there will be substantial leakage from between the motor adaptor and brake housing.</li> <li>c) Insufficient hydraulic pressure. (See SPECIFICATIONS for minimum operating pressure.)</li> <li>d) Winch is mounted to an uneven surface. (See INSTALLATION INSTRUCTIONS.)</li> <li>e) Hydraulic pressure is not reaching the brake piston (plugged brake release orifice in the brake housing).</li> </ul>

# TROUBLE SHOOTING CONTINUED

FAILURE	PROBABLE CAUSE
<b>Brake will not hold.</b>	<ul style="list-style-type: none"> <li>a) Brake plates or divider plates have been damaged by contamination in the hydraulic fluid, or lack of circulation flow in the brake housing.</li> <li>b) Brake piston is seized in the brake housing because of contamination in the hydraulic fluid.</li> <li>c) Excessive back pressure in the return line causes the brake to be released.</li> <li>d) Control valve has incorrect spool, which traps hydraulic pressure in the brake piston when the control valve handle is returned to neutral position. For proper function of the automatic brake, both pressure ports of the winch must be open to the reservoir in neutral position of the control valve.</li> <li>e) Wire rope is fastened to the incorrect cable anchor slot.</li> <li>f) Sprag clutch is damaged or surfaces where sprag clutch engages on motor drive shaft or brake hub are worn or indented.</li> <li>g) Winch supplied with external brake release option is not plumbed per HYDRAULIC CIRCUIT. Failure to vent external brake release port to reservoir may trap pressure and cause winch brake to slip.</li> </ul>
<b>Brake vibrates when lowering a load.</b>	<ul style="list-style-type: none"> <li>a) Pump is too slow. Pump rpm must be maintained at normal operating speed when a load is lowered.</li> <li>b) Brake is running too hot. This is caused by a complete lack of, or insufficient circulation flow. To check the circulation, observe the flow of oil from the circulation return line of the winch (see TYPICAL HYDRAULIC CIRCUIT) when the winch is reversed.</li> <li>c) Control valve has poor metering characteristics.</li> <li>d) Damaged brake plates or divider plates.</li> <li>e) The over-running clutch, which connects the motor shaft with the brake assembly, is damaged.</li> <li>f) Air mixed with hydraulic oil (foamy oil).</li> </ul>
<b>Oil leaks.</b>	<ul style="list-style-type: none"> <li>a) Oil leaks from the hydraulic motor flange and the motor adaptor are caused by damaged O-ring seals.</li> <li>b) Oil leaks occurring between the cable drum flanges and housings are caused by excessive pressure in the brake housing. Excessive pressure will damage the oil seal which separates the brake housing from the cable drum interior.</li> <li>c) If the breather relief on the end cover leaks, the seal between the drum interior and the brake housing is damaged and must be replaced. This condition is caused by excessive pressure in the brake housing of the winch, operation with the incorrect hydraulic fluid during cold weather, or a restriction in the circulation return line leading back to tank.</li> </ul>

Refer to the SERVICE INSTRUCTIONS if it becomes necessary to disassemble the Model M30 winch.

# SERVICE INSTRUCTIONS

## GENERAL:

Before attempting disassembly of the PULLMASTER Model M30 planetary winch, the following instructions for disassembly and reassembly should be read and understood:

It is suggested that all expendable parts, such as O-rings and oil seals, are not reused on reassembly. It is therefore important to have a seal kit (Part No. 23408) and, providing the hydraulic motor has to be serviced, a seal kit (Part No. 23117) on hand before the unit is taken apart. Two new roller bearings item 875, may also be required.

## NOTE:

Backup washers may be included with seal kit. Install with oil seals as per instructions. If not present in seal kit, the oil seals supplied do not require backup washers.

A clean working area is of prime importance, similar to conditions used for service work on any other hydraulic component.

All parts, as they are removed from the winch assembly, should be inspected for wear and damage. Worn or damaged parts must be replaced. Thoroughly clean parts before reassembly. Do not use solvent to clean the brake friction plates.

During reassembly, lubricate all O-rings and oils seals with grease before installation.

In the following service instructions, reference to parts is made by numbers and shown on the applicable group drawings.

## DISASSEMBLY

For the majority of required service or repair work, disassembly is required only on the brake housing of the PULLMASTER Model M30 planetary winch. There are no special tools needed for the service or repair work and no adjustments or calibrations are necessary. Proceed with the disassembly as follows:

### DISASSEMBLY OF HYDRAULIC MOTOR ASSEMBLY:

If the analyzed service or repair work requires access to the interior of the brake housing, the hydraulic motor should not be disassembled. In this case, the hydraulic motor should be removed together with the motor adaptor as a complete assembly. If a problem has been analyzed to be in the hydraulic motor, proceed with the disassembly as follows:

1. Remove the eight hex capscrews item 951, together with the lockwashers item 953, from the motor assembly.

**IMPORTANT:** Failure to exercise care when removing the motor port end cover or gear housing could permanently damage the machined surfaces of these motor components. Take care not to damage machined surfaces of motor components at disassembly.

2. Remove (pry loose if necessary) port end cover item 870, together with bearings item 875, and ring seal item 877. Thrust plate item 885, and dowel pins item 865, may stay in gear housing.
3. If thrust plate comes off with end cover, carefully pry it off of bearings item 875, and discard pocket seals item 887.



# SERVICE INSTRUCTIONS CONTINUED

4. Remove gear set item 881, which consists of two gears which are a matched set.
5. Carefully pry gear housing item 861, off of the motor adaptor item 800. Thrust plate item 885, and dowel pins item 865, may stay in the gear housing.
6. If the thrust plate stays on the motor adaptor, carefully pry it off of bearings item 875 and discard teflon seals item 887.
7. Discard gasket seals item 869. It is also advisable to replace ring seals item 877, at this time. Bearings item 875, have to be removed to allow access to ring seals.

Teflon seals, gasket seals and ring seals in the hydraulic motor assembly are not part of the winch seal kit. The seal kit for the hydraulic motor can be ordered from the factory under Part No. 23117. All parts of the hydraulic motor, with the exception of the motor adaptor, item 800, and the port end cover, item 870, are standard parts of the hydraulic motor, having a 3 inch gear section. All of these parts can be ordered from PULLMASTER or authorized Distributors/Dealers in Canada, the United States and in most overseas areas.

## **REMOVAL OF HYDRAULIC MOTOR ASSEMBLY:**

If disassembly of the hydraulic motor is not necessary proceed as follows:

1. Remove 12 hex capscrews item 537, with lockwashers item 541, from motor adaptor item 800. (Since the brake springs item 752, apply pressure against the inside of the motor adaptor, it is recommended that the hex capscrews are unscrewed, one turn at a time, until the spring pressure has been released.) The complete motor assembly, including motor adaptor, can now be removed from brake housing assembly.
2. Remove and discard three O-rings item 801, and O-ring item 707. (O-rings item 801, seal the pressure transfer hole for the automatic brake release and are situated on the flange of the brake housing.)

## **DISASSEMBLY OF BRAKE HOUSING ASSEMBLY:**

1. After motor assembly has been removed, all parts of brake assembly are accessible. Remove 14 brake springs item 752. Thoroughly examine springs for damage and measure overall length. Overall spring length should be 2.27 inch. If any spring measures less than 2.21 inch, replace all springs as a set.
2. Pull motor drive shaft item 730, and complete brake hub assembly from brake housing.
3. Disassemble brake hub assembly by removing circlips, 727 and 719 from motor drive shaft. Remove motor drive shaft from brake hub item 720. Remove sprag clutch aligners items 722 and 724, and sprag clutch item 723, from brake hub.



**DANGER**

**MINOR SURFACE DEFECTS WHERE THE SPRAG CLUTCH ENGAGES THE MOTOR DRIVE SHAFT AND BRAKE HUB, WILL RESULT IN BRAKE FAILURE AND ALLOW THE LOAD TO DROP, CAUSING PROPERTY DAMAGE SEVERE INJURY OR DEATH. THOROUGHLY INSPECT THESE AREAS AND, IF NECESSARY, REPLACE MOTOR DRIVE SHAFT, SPRAG CLUTCH AND CONNECTING SHAFT AS A SET.**

# SERVICE INSTRUCTIONS CONTINUED

4. Thoroughly inspect motor drive shaft item 730, and brake hub item 720, particularly the surfaces where sprag clutch item 723, engages. If any indentation or surface damage is detected, replace brake hub, sprag clutch and motor drive shaft as a set.
5. Pull brake piston item 750, out of brake housing using two 5/8-11NC bolts screwed into two puller holes in piston and discard O-rings item 751 and item 753.
6. Thoroughly examine inner bores of brake housing and outer diameters of brake piston for scoring caused by hydraulic fluid contamination. Minor surface damage may be repaired by polishing with a fine emery cloth.



**DANGER**

**DAMAGED FRICTION OR DIVIDER PLATES WILL REDUCE BRAKING CAPACITY AND ALLOW THE LOAD TO DROP, CAUSING PROPERTY DAMAGE, SEVERE INJURY OR DEATH. SOLVENT MAY DAMAGE THE FRICTION PLATES. DO NOT USE SOLVENT TO CLEAN THE FRICTION PLATES. PERFORM THOROUGH INSPECTION AND, IF NECESSARY, REPLACE FRICTION AND DIVIDER PLATES AS A SET.**

7. Remove five friction plates item 715, together with six divider plates item 713, and inspect for damage or wear. Plates should be flat and smooth. Plates should not show heat discoloration. Paper material on friction plates should be intact and grooved. If any damage is detected, replace friction and divider plates as a set.
8. Remove brake spacer item 712.

## **DISASSEMBLY OF FINAL DRIVE:**

- 1) Remove drain plug item 121, from end cover item 120, and drain lubricating oil from final drive assembly and cable drum interior. (To drain all oil out of cable drum interior, winch should be tipped to an angle and filler plug item 503, removed.
- 2) Remove eight hex capscrews item 127 and lockwashers item 129, and pull end cover item 120, from final drive housing item 100.
- 3) Discard O-ring item 123, and inspect planet hub stopper item 126, and sungear stopper item 122, for excessive wear. Replace planet hub stopper if less than 0.30 inch thick and sungear stopper if less than 0.21 inch thick.
- 4) Remove final planet hub assembly from final housing item 100.
- 5) Inspect three final planet gears item 320, for damage or wear. If necessary to remove final planet gears, remove circlip item 311, and press planet pin item 310, out of planet hub item 300. Inspect loose rollers item 323, and two thrust washers item 321, and replace if damaged.

## **DISASSEMBLY OF PRIMARY DRIVE AND CABLE DRUM ASSEMBLY:**

For ease of working on remainder of unit, set winch upright on final drive housing.

- 1) Remove four hex capscrews item 555 with lockwashers item 553 from each side of both tie bars item 556, and take the tie bars from the assembly.
- 2) Remove access plug item 734, using a ½ – 13NC bolt (motor adaptor bolt item 821, is suitable), from inside brake housing and discard O-ring item 735.

# SERVICE INSTRUCTIONS CONTINUED

- 3) Remove six hex capscrews item 537, with lockwashers item 541, from bearing flange item 530, by rotating brake housing until access hole is over top.
- 4) Lift brake housing together with the bearing flange and primary planet hub assembly, out of cable drum item 500, and discard O-ring item 539.
- 5) Remove final sungear item 340, from cable drum item 500.
- 7) Inspect three primary planet gears item 420, for damage or wear. If necessary to remove primary planet gears, remove circlip item 411, and press planet pin item 410, out of planet hub item 400. Inspect loose rollers item 423, and two thrust washers item 421, and replace if damaged.
- 8) Remove primary sungear item 440, from center of connecting shaft item 600.
- 9) Remove circlip item 431, and internal gear item 430, from connecting shaft spline.
- 10) Remove spacer item 434.
- 11) Pull connecting shaft item 600, out of brake housing. Discard O-ring item 601.
- 12) Remove and discard oil seal item 607, and if present, backup washer item 606, from inside of connecting shaft.
- 13) Remove needle bearing item 603. Inspect and replace if damaged.
- 14) Separate bearing flange item 530, and brake housing item 700, using a standard bearing puller or insert two heel bars in slot between bearing flange and brake housing. Pry brake housing out of cylindrical bearing item 533.
- 15) Remove internal retaining ring item 534, and remove the outer race and caged roller assembly of cylindrical roller bearing item 533. (Two ¼ NPT pipe plugs in bearing flange item 530, can be removed to facilitate bearing removal).
- 16) Remove and discard oil seal item 531.
- 17) Inspect the separate inner race of cylindrical roller bearing item 533, and if damaged remove from brake housing item 700.
- 18) Separate cable drum from final housing by first removing circlip item 513. Insert two heel bars between flange of cable drum and final drive housing and gently pry cable drum out of ball bearing item 103.
- 19) Remove internal circlip item 109, to remove ball bearing item 103. Remove and discard oil seal item 105.

## **REASSEMBLY**

Thoroughly clean all parts. Use only new, well-greased O-rings and oil seals. Unless otherwise specified, torque fasteners per BOLT TORQUE CHART at back of manual.

## **REASSEMBLY OF FINAL DRIVE**

Reassemble final drive end of winch as follows:

- 1) Press new, well-greased oil seal item 105, into final housing item 100.
- 2) Press ball bearing item 103, into final housing and secure with circlip item 109.

# SERVICE INSTRUCTIONS<sub>CONTINUED</sub>

- 3) Press cable drum item 500, into ball bearing item 103, and secure with circlip item 513.
- 4) Reassemble final planet hub assembly. Use grease to temporarily hold 24 loose rollers item 323, in bore of planet gear item 320. Position thrust washers item 321, on either side of planet gear and press planet pin item 310, into final planet hub item 300. Retain with circlip item 311.
- 5) Insert final planet hub assembly into final housing item 100. Ensure that final planet hub spline is fully engaged with cable drum item 500.
- 6) Install new, well-greased O-ring item 123, into end cover item 120. Verify that planet hub stopper item 126, and sungear stopper item 122, are installed into end cover.
- 7) Gently insert end cover into final housing item 100, and fasten using 8 hex capscrew item 127, and 8 lockwashers item 129.

## **REASSEMBLY OF PRIMARY DRIVE:**

Turn winch over, resting on end cover with cable drum opening facing up. Reassemble primary drive as follows:

NOTE: Care must be take when handling the assembly at this stage, avoid separation of the bearing flange subassembly and brake housing.

- 1) Press new, well-greased oil seal item 531, into bearing flange item 530. Press outer race complete with caged, roller assembly of cylindrical roller bearing item 533 into bearing flange and secure with retaining ring item 534. Verify two ¼ NPT pipe plugs are installed in bearing flange item 530.
- 2) Install bearing flange assembly onto brake housing and then press the inner race of cylindrical roller bearing item 533 onto brake housing item 700, and install new, well-greased O-ring item 539.
- 3) Press needle bearing item 603, into connecting shaft item 600.
- 4) Install new, well-greased oil seal item 607, into connecting shaft.
- 5) Install new, well-greased O-ring item 601, onto connecting shaft, item 600, and insert connecting shaft into brake housing item 700.
- 6) Slide internal gear item 430, along with spacer item 434, onto end of connecting shaft and fasten in place with circlip item 431.
- 7) Reassemble primary planet hub assembly. Use grease to temporarily hold 20 loose rollers item 423, in bore of planet gear item 420. Verify placement of sungear stopper item 444. Position thrust washers item 421, on either side of planet gear and press planet pin item 410, into primary planet hub item 400. Retain with circlip item 411.
- 8) Insert primary sungear item 440, between three planet gears and insert sungear shaft into connecting shaft, engaging planet gears with internal gear. Fasten with retaining ring item 401.
- 9) Insert final sungear item 340, into cable drum and engage three planet gears item 320. If final sungear is installed, verify that circlip item 343, is in place on final sungear.
- 10) Lower brake housing assembly onto cable drum, while engaging spline of final sungear with primary planet hub item 400. Line up mounting holes of bearing flange item 530, with those in cable drum.

# SERVICE INSTRUCTIONS<sub>CONTINUED</sub>

- 11) Rotate brake housing to line up access holes and fasten bearing flange using six capscrews item 537, and lockwashers item 541.
- 12) Install new, well-greased O-ring item 735, into access plug item 734. Install access plug into access hole inside brake housing.
- 13) Fasten two tie bars item 556, using 16 capscrews item 555, and lockwashers item 553.

## REASSEMBLY OF BRAKE HOUSING ASSEMBLY

Reassemble brake housing assembly as follows:

- 1) Install sprag clutch item 723, into bore of brake hub item 720. Position sprag clutch aligners items 722 and 724, on either side of brake hub. Carefully slide motor drive shaft item 730, into brake hub assembly and secure with circlip item 727. Verify that circlips items 719 and 731, are installed on motor drive shaft.
- 2) Carefully slide motor drive shaft item 730, with brake hub assembly, into connecting shaft until it engages spline of primary sungear item 440.

**IMPORTANT:** For proper brake function, verify that sprag clutch is installed correctly. When viewed from the motor end, the motor drive shaft of a clockwise hoisting winch must turn freely clockwise and lock in the counterclockwise direction.

- 3) Install brake spacer item 712, into brake housing.



**DANGER**

**INCORRECT ASSEMBLY OF THE FRICTION PLATE AND DIVIDER PLATE STACK WILL REDUCE BRAKING CAPACITY AND ALLOW THE LOAD TO DROP, CAUSING PROPERTY DAMAGE, SEVERE INJURY OR DEATH REASSEMBLE PER INSTRUCTIONS.**

- 4) Starting and finishing with a divider plate, alternately install six divider plates item 713, and five friction plates item 715.
- 5) Liberally grease O-ring item 751, and O-ring item 753, and install on brake piston item 750.
- 6) Slide brake piston item 750, into brake housing item 700, with holes for brake springs facing out of brake housing assembly.
- 7) Install 14 brake springs item 752, in brake piston using hole pattern shown.

LOCATION OF  
BRAKE SPRINGS  
(FOURTEEN SPRINGS,  
TWENTY HOLES)

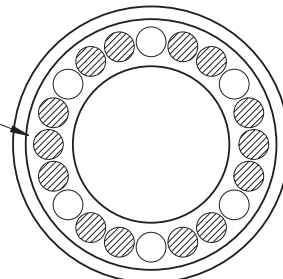

# SERVICE INSTRUCTIONS<sub>CONTINUED</sub>

- 8) Liberally grease three new O-rings item 801, and install into recesses on motor adaptor item 800. Install new, well-greased O-ring item 707, on flange of motor adaptor.
- 9) Slide hydraulic motor assembly onto splined end of motor drive shaft item 730, and line up pressure transfer holes of brake housing and motor adaptor. Install 12 capscrews item 821, and lockwashers item 823. Tighten one turn at a time to evenly compress springs.

## REASSEMBLY OF HYDRAULIC MOTOR:

If the hydraulic motor was disassembled, the following procedure should be followed for reassembly:

1. Clean all parts thoroughly before reassembly and apply grease liberally to all seals. Use only new seals (seal kit Part No. 23117) for hydraulic motor.
2. Install two new teflon seals item 887, on each thrust plate item 885. Press one of the thrust plates, together with two teflon seals, onto bearings item 875, installed in motor adaptor item 800.
3. Install new, well-greased gasket seal item 869, on each side of gear housing item 861. Slide gear housing together with gasket seals, onto motor adaptor, lined up on two dowel pins. Tap on tight using a soft headed hammer.
4. Install gear set item 881, into gear housing. (Longer gear with internal spline goes into top position.)
5. Press other thrust plate, complete with two new teflon seals, onto bearings installed in port end cover.
6. Install port end cover item 870, together with two bearings item 875, and new ring seal item 877, onto gear housing, lined up on two dowel pins item 865. Tap on tight using soft headed hammer. Install and lightly torque eight hex capscrews item 951, and lockwashers item 953, to approximately 50 ft-lb (70 Nm).
7. Plumb winch assembly to a hydraulic supply and torque motor capscrews according to the following procedure:
  - Ensure that circulation supply flow is being supplied to the brake housing.
  - Run the winch, with no load, in the hoisting direction at reduced speed (approximately 30% of maximum hydraulic volume).
  - With winch running, evenly tighten eight capscrews item 951, to 200 ft-lb (270 Nm).
  - Test motor operation by running winch at full speed in both directions.

**IMPORTANT:** Before operating the winch, add lubricating oil up to the level of the end cover oil fill port. (Refer to **INSTALLATION INSTRUCTIONS** for location of fill port. Refer to **APPENDIX A** for oil volume required.)

To ensure proper reassembly, run the winch in both directions without load.



**DANGER**

**LIFTING A LOAD WITH A NEWLY SERVICED WINCH COULD ENABLE AN INSTALLATION OR SERVICE PROBLEM TO GO UNDETECTED WHICH WILL ALLOW THE LOAD TO DROP CAUSING PROPERTY DAMAGE, SEVERE INJURY OR DEATH. TO ENSURE PROPER REINSTALLATION, REFER TO PROCEDURES AND TESTS DESCRIBED IN "INSTALLATION" AND "OPERATING INSTRUCTIONS".**

# RECOMMENDED MAINTENANCE

Winch gear train lubricating oil should be changed after the initial six months or 50 hours of operation, whichever comes first. Lubricating oil should then be changed every 12 months or 500 operating hours, whichever comes first.

Hydraulic system fluid should be changed at least once every 12 months.

For optimum performance over an extended period of time, the following preventive maintenance service should be done every 12 months or 500 operating hours (whichever comes first):

- 1) Disconnect all hydraulic hoses and remove the winch from its mounting.
- 2) Disassemble the winch as per instructions.
- 3) Discard and replace all O-rings and oil seals.
- 4) Clean all parts and inspect for wear and damage as per instructions. Replace worn or damaged parts as required.
- 5) Reassemble the winch as per instructions.
- 6) Follow INSTALLATION and OPERATING INSTRUCTIONS when returning winch to its mounting.

When ordering parts for the PULLMASTER Model M30 planetary winch, always quote the complete model and serial number of the unit.

**MODEL NO.** \_\_\_\_\_

**SERIAL NO.** \_\_\_\_\_

PULLMASTER WINCH CORPORATION reserves the right to change specifications and the design of PULLMASTER planetary winches at any time without prior notice and without incurring any obligations.

# ASSEMBLY DRAWING

AS-M30

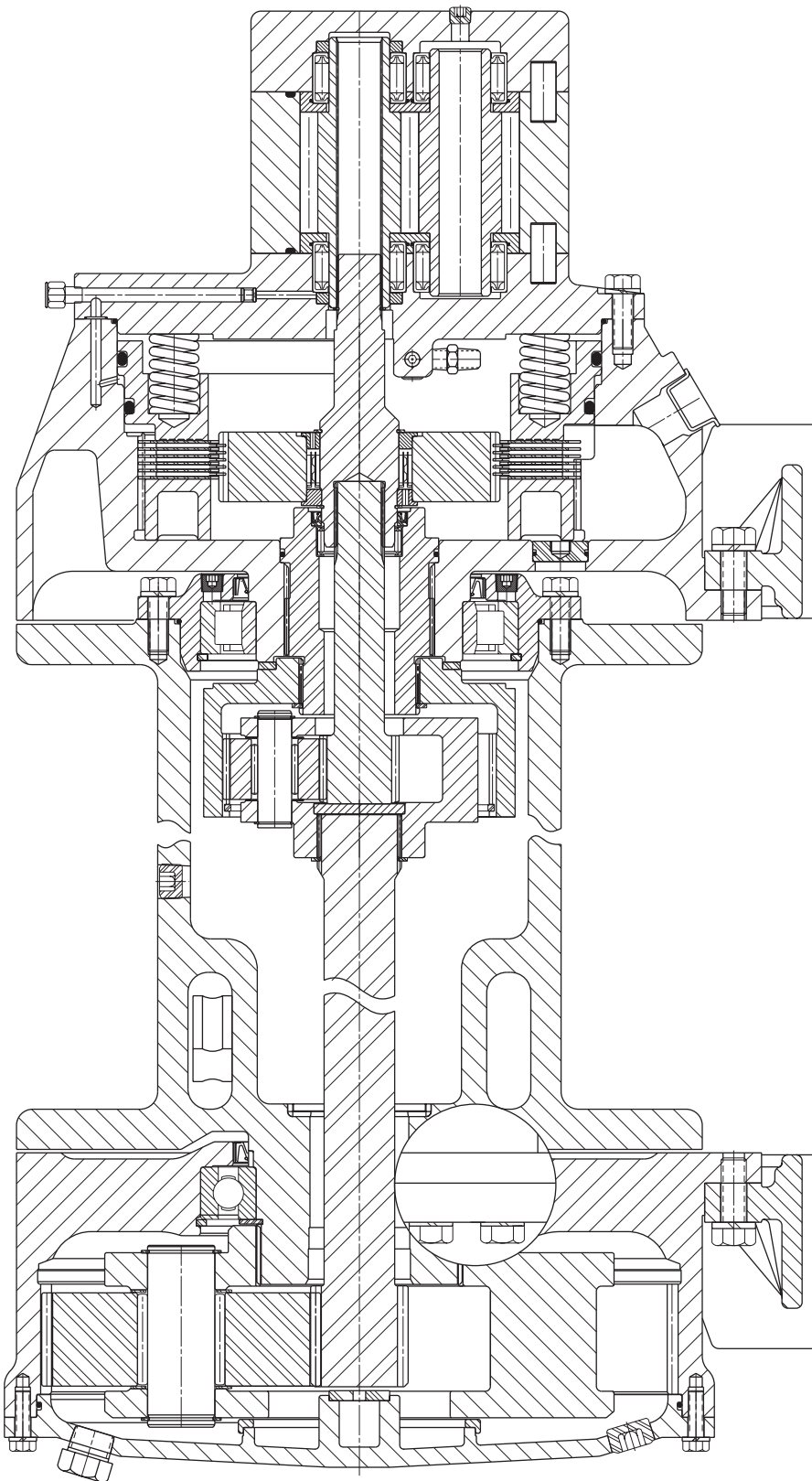



# PARTS REFERENCE - FINAL DRIVE

ITEM NO.	QTY.	PART NO.	DESCRIPTION
100	1	*	FINAL HOUSING
103	1	25333	BALL BEARING # 6026
104	1	26467	CIRCLIP ROTOR DHO-200
105	1	25148	OIL SEAL
120	1	23623	END COVER
121	2	25237	PIPE PLUG 3/4 - 14 NPT
122	1	19036	SUNGEAR STOPPER
123	1	25340	O-RING-281 15" ID 1/8" CS
126	1	20418	PLANET HUB STOPPER
127	8	25118	CAPSCREW HEX HEAD 3/8-16 NC X 1.25 GRADE 5
129	8	25037	LOCK WASHER 3/8"
130	1	20677	BREATHER RELIEF ASSEMBLY
300	1	**	PLANET HUB
310	3	20406	PLANET PIN
311	6	25199	CIRCLIP ROTOR CLIP SH-168
320	3	**	PLANET GEAR
321	6	25167	THRUST WASHER TORRINGTON # TRB 2840
323	72	25297	LOOSE ROLLER TORRINGTON # 024054
340	1	*	SUNGEAR
343	1	25700	CIRCLIP ROTOR CLIP SH-206
500	1	*	CABLE DRUM
502	1	20423	CABLE ANCHOR
503	1	25032	PIPE PLUG 1/2-14 NPT
513	1	25514	CIRCLIP ROTOR CLIP SH-500
551	*	25346	CAPSCREW - HEX HEAD 5/8 -11 NC GRADE 5
553	*	25359	LOCKWASHER 5/8"
554	2	*	BASE PLATE
555	16	*	CAPSCREW - HEX HEAD 5/8 - 11 NC GRADE 5
556	2	*	TIE BAR

\* These part numbers vary according to drum code.  
Refer to APPENDIX B.

\*\* These parts vary according to Reduction Ration.  
Refer to APPENDIX C.

# FINAL DRIVE GROUP

G1190-A

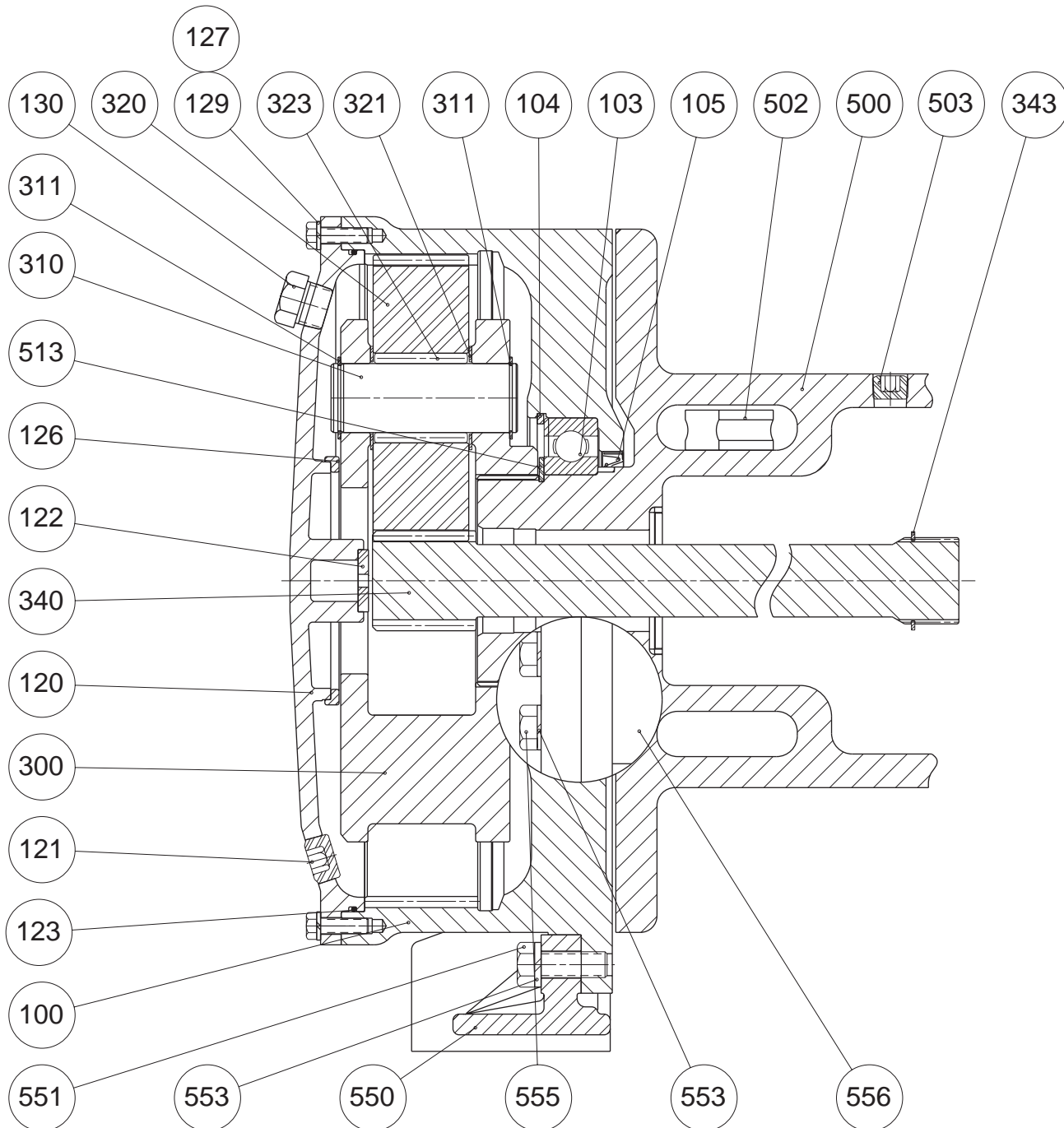

Group drawings may reference more parts than are actually present in a specific assembly. Parts that are referenced on the drawing but are not on the PARTS REFERENCE list should be ignored.

# PARTS REFERENCE - BRAKE GROUP

ITEM NO.	QTY.	PART NO.	DESCRIPTION
400	1	**	PLANET HUB
401	1	20417	RETAINING RING
410	3	20369	PLANET PIN
411	3	25004	CIRCLIP ROTOR CLIP C-87
413	3	25091	CIRCLIP ROTOR CLIP SH-87
420	3	**	PLANET GEAR
421	6	25068	THRUST WASHER TORRINGTON # TRA 1423
423	45	25308	LOOSE ROLLER 5/32 X 1.25 TOR. #E151-Q
430	1	**	INTERNAL GEAR
431	1	25338	CIRCLIP ROTOR CLIP SH-300
434	1	20452	SPACER
440	1	**	SUNGEAR
444	1	21809	SUNGEAR STOPPER
530	1	23175	BEARING FLANGE
531	1	26359	OIL SEAL
533	1	26464	CYLINDRICAL ROLLER BEARING # NU 1026
534	1	20461	BEARING RETAINER
537	6	25081	CAPSCREW - HEX HEAD 1/2 - 13NC X 1.50 GRADE 5
539	1	25109	O-RING-269 8-3/4" ID 1/8" CS
541	6	25014	LOCK WASHER 1/2"
600	1	20445	CONNECTING SHAFT
601	1	25341	O-RING-239 3-5/8" ID 1/8" CS
603	1	25334	NEEDLE BEARING TORRINGTON # B2812
606	1	21086	BACKUP WASHER
607	1	25345	OIL SEAL
700	1	*	BRAKE HOUSING
703	1	25347	PLASTIC CAPPLUG 1 NPT THR'D
707	1	25339	O-RING-278 12" ID 1/8" CS
712	1	20451	BRAKE SPACER
713	6	25305	DIVIDER PLATE
715	5	25304	FRICTION PLATE
719	1	25336	CIRCLIP ROTOR CLIP SH-187
720	1	20446	BRAKE HUB
722	1	20455	SPRAG CLUTCH ALIGNER
723	1	25303	SPRAG CLUTCH BORG WARNER #140373 B
724	1	20421	SPRAG CLUTCH ALIGNER
727	1	25335	CIRCLIP ROTOR CLIP SH-196
734	1	20422	PLUG
735	1	25344	O-RING-123 1-3/16" ID 3/32" CS
750	1	20397	PISTON
751	1	25343	O-RING-90 DURO-451 11" ID 1/4" CS
752	14	20413	BRAKE SPRING
753	1	25342	O-RING-90 DURO-452 11-1/2" ID 1/4" CS
		23408	WINCH SEAL KIT, CONSISTS OF ITEMS: 105,123,531,539,601,606,607,707,735,751,753 AND 801
			* This part varies according to drum code. Refer to APPENDIX B.
			** These parts vary according to Reduction Ratio. Refer to APPENDIX D.

Refer to PAGE 22 for ASSEMBLY DRAWING.

# BRAKE GROUP

G1189-B

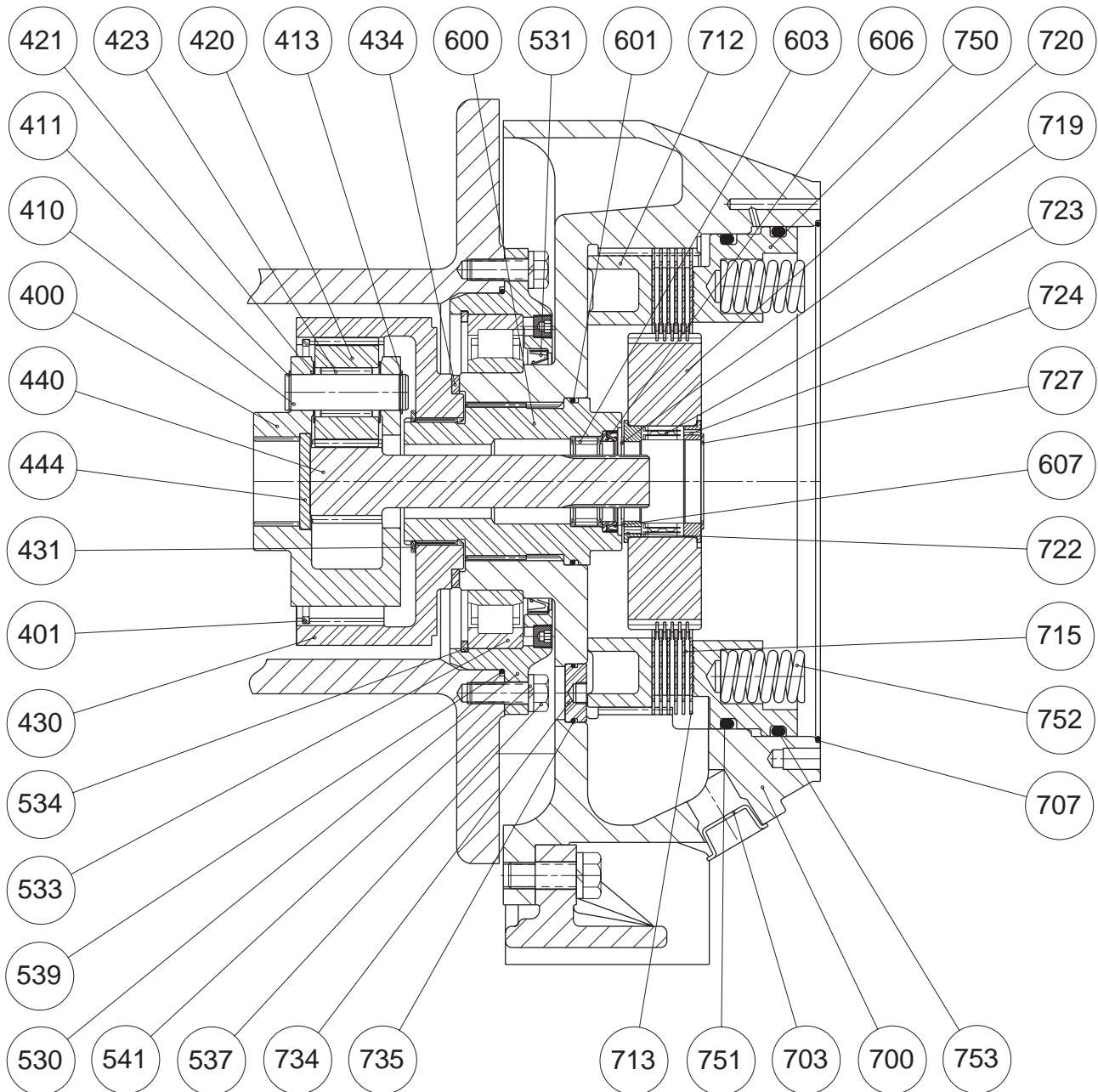

Group drawings may reference more parts than are actually present in a specific assembly. Parts that are referenced on the drawing but are not on the PARTS REFERENCE list should be ignored.

# PARTS REFERENCE - MOTOR GROUP

ITEM NO.	QTY.	PART NO.	DESCRIPTION
537	12	25081	CAPSCREW - HEX HEAD 1/2-13NC X 1.5 GRADE 5
541	12	25014	LOCKWASHER 1/2"
730	1	23601	MOTOR DRIVE SHAFT
731	1	25288	CIRCLIP ROTOR CLIP C-112
800	1	20401	MOTOR ADAPTOR
801	3	25127	O-RING -013 7/16" ID 1/16" CS
802	1	*	*
805	2	25040	PIPE PLUG 1/8 - 27 NPT
806	1	*	*
807	1	*	*
809	1	*	*
813	1	25031	PIPE PLUG 1/4 - 18 NPT
861	1	25350	GEAR HOUSING -086
865	4	25356	DOWEL PIN
869	2	25348	GASKET SEAL
870	1	26443	PORT END COVER WITH PLUGS
875	4	25352	ROLLER BEARING
877	2	25646	RING SEAL
881	1	25645	GEAR SET
885	2	25644	THRUST PLATE
887	4	25647	TEFLON SEAL
929	1	*	*
950**	1	*	SUB - ASSY MOTOR -086
951	8	25357	CAPSCREW - HEX HEAD 5/8 X 6.75 GRADE 5
953	8	25325	WASHER
955	2	25559	PLASTIC CAPLUG 2.0"
		23117	MOTOR SEAL KIT, CONSISTS OF ITEMS: 869, 877 AND 887
			* These part numbers and descriptions vary according to brake code. Refer to APPENDIX C.
			** ITEM 950, MOTOR SUB-ASSY, CONTAINS ITEMS: 800, 802, 803, 804, 805, 807, 809, 861, 865, 869, 870, 875, 877, 881, 885, 887, 929, 951, 953 AND 955

Refer to PAGE 25 for winch seal kit and PAGE 22 for ASSEMBLY DRAWING.

# MOTOR GROUP

G1002-D

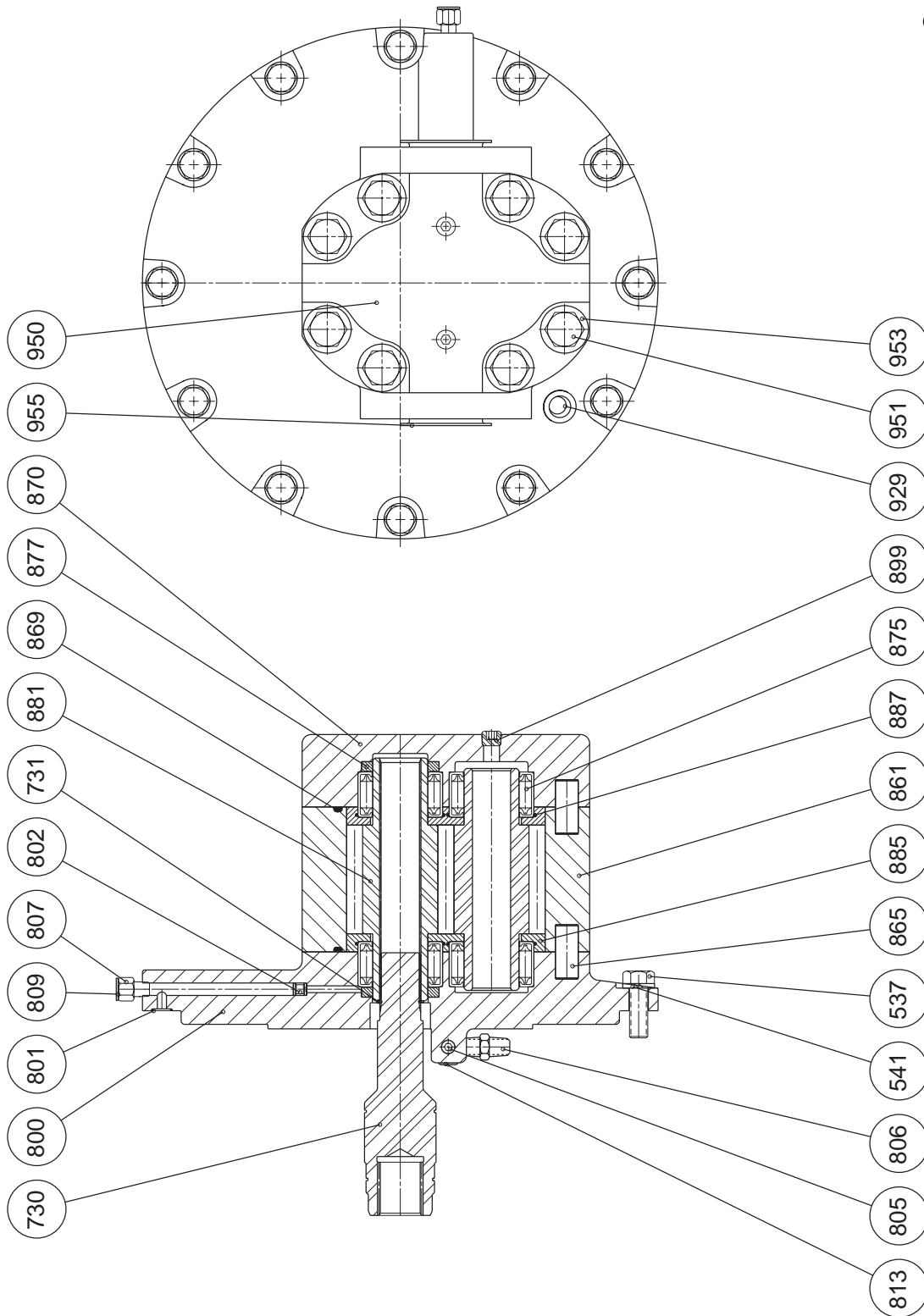

Group drawings may reference more parts than are actually present in a specific assembly. Parts that are referenced on the drawing but are not on the PARTS REFERENCE list should be ignored.

# INSTALLATION DRAWING

I1102-1

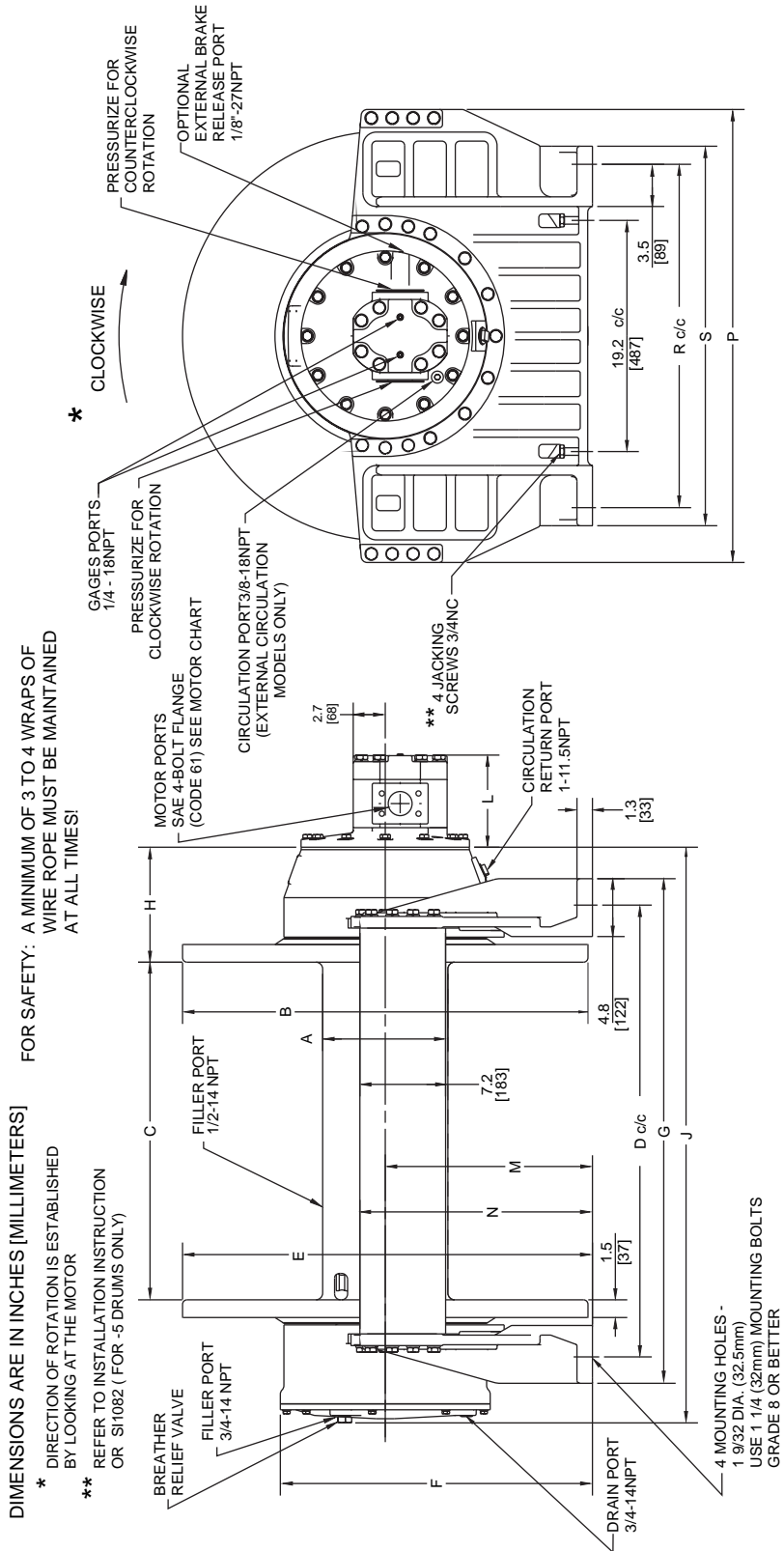

# INSTALLATION DIMENSIONS

I1102-2

**Dimensions in inches  
(Dimensions in millimeters)**

DRUM CODE	A	B	C	D	E	F	G	H	J	M	N	P	R	S
-1	10.0 (254)	17.0 (432)	11.0 (279)	18.500 (469.90)	19.9 (505)	20.18 (513)	22.9 (582)	8.6 (218)	28.8 (732)	11.38 (289)	14.2 (361)	20.8 (523)	17.750 (450.85)	20.8 (527)
-2	10.0 (254)	24.0 (610)	11.0 (279)	18.500 (469.90)	24.4 (619)	21.3 (538)	22.9 (592)	8.6 (218)	28.8 (732)	12.4 (315)	17.5 (445)	27.6 (701)	22.875 (581.03)	25.9 (658)
-3	10.0 (254)	24.0 (610)	17.0 (432)	24.500 (622.30)	24.4 (619)	21.3 (538)	28.9 (734)	8.6 (218)	34.8 (884)	12.4 (315)	17.5 (445)	27.6 (701)	22.875 (581.03)	25.9 (658)
-4	10.0 (254)	24.0 (610)	22.0 (559)	29.500 (749.30)	24.4 (619)	21.3 (538)	33.9 (836)	8.6 (218)	39.8 (1011)	12.4 (315)	17.5 (445)	27.6 (701)	22.875 (581.03)	25.9 (658)
-5	10.0 (254)	34.0 (864)	28.0 (712)	37.500 (952.50)	34.4 (875)	26.2 (665)	41.9 (1064)	9.6 (244)	47.8 (1214)	17.4 (441)	19.5 (495)	37.6 (955)	28.500 (723.90)	31.5 (800)
-14	14.5 (368)	24.0 (610)	17.0 (432)	24.500 (622)	24.4 (620)	21.2 (538)	28.9 (734)	8.6 (218)	34.8 (884)	12.4 (315)	17.5 (445)	27.6 (701)	22.875 (581.03)	25.9 (658)

HYDRAULIC MOTORS				
COMMERCIAL WM76 SERIES				
MOTOR CODE	GEAR WIDTH	MOTOR PORT SIZE SAE SPLIT FLANGE	L	
-86	3.00	2.0	7.6	(194)
-87	2.75	(CODE 61)	7.4	(187)
-88	2.50	1.5 (CODE 61)	7.1	(181)
-89	2.25		6.9	(175)
-90	2.00		6.6	(168)
-91	1.75	1.25 (CODE 61)	6.4	(162)
-92	1.50		6.1	(156)
-93	1.25		5.9	(149)
-94	1.00	1.0 (CODE 61)	5.6	(143)



# APPENDIX A

DRUM CODE	CABLE DRUM SIZES INCHES (MILLIMETERS)			WIRE ROPE STORAGE FEET (METERS)			LINE PULL AT MAXIMUM PRESSURE*		LINE SPEED AT MAXIMUM VOLUME*		LUBRICATING OIL VOLUME REQUIRED  U.S. GALLONS (LITERS)
	BARREL	FLANGE	LENGTH	3/4 inch	7/8 inch	1 inch	BARE DRUM	FULL DRUM	BARE DRUM	FULL DRUM	
-1	10.0 (254)	17.0 (432)	11.0 (279)	210 (64)	140 (43)	91 (28)	25000 (111.2)	16860 (75.0)	140 (43)	207 (63)	2.3 (8.7)
-2	10.0 (254)	24.0 (610)	11.0 (279)	515 (157)	398 (121)	264 (80)	25000 (111.2)	11757 (52.3)	140 (43)	297 (90)	2.3 (8.7)
-3	10.0 (254)	24.0 (610)	17.0 (432)	796 (243)	615 (187)	408 (124)	25000 (111.2)	11757 (52.3)	140 (43)	297 (90)	3.0 (11.3)
-4	10.0 (254)	24.0 (610)	22.0 (559)	1031 (314)	796 (243)	528 (161)	25000 (111.2)	11757 (52.3)	140 (43)	297 (90)	3.6 (13.6)
-5	10.0 (254)	34.0 (864)	29.0 (737)	3189 (972)	2204 (672)	1689 (515)	25000 (111.2)	8208 (36.5)	140 (43)	425 (130)	4.4 (16.6)
-10	10.0 (254)	17.0 (432)	29.0 (737)	555 (169)	370 (113)	241 (73)	25000 (111.2)	16860 (75.0)	140 (43)	207 (63)	4.4 (16.6)
-14	14.5 (368)	24.0 (610)	17.0 (432)	647 (197)	468 (143)	344 (105)	17683 (78.7)	11757 (52.3)	197 (60)	297 (90)	5.7 (21.5)
-31	13.0 (330)	24.0 (610)	17.0 (432)	705 (215)	523 (159)	397 (121)	19595 (87.2)	11757 (52.3)	178 (54)	297 (90)	4.4 (16.6)

\* Performance specifications are based on standard hydraulic motor with 7/8 inch diameter rope.

# APPENDIX B

ITEM NO	PART DESCRIPTION	DRUM CODE							
		-1	-2	-3	-4	-5	-10	-14	-31
		PART NUMBER (QUANTITY)							
100	FINAL HOUSING	23346 (1)	23534 (1)	23534 (1)	23534 (1)	23534 (1)	23346 (1)	23534 (1)	23534 (1)
340	FINAL SUNGEAR (STANDARD RATIO)	N/A	N/A	N/A	23585 (1)	23629 (1)	23629 (1)	N/A	N/A
340	FINAL SUNGEAR ("F" RATIO)	N/A	N/A	N/A	N/A	N/A	N/A	23786 (1)	N/A
500	CABLE DRUM	23295 (1)	23299 (1)	23293 (1)	23301 (1)	23303 (1)	23306 (1)	23307 (1)	23308 (1)
550	BASE PLATE	23272 (2)	23283 (2)	23283 (2)	23283 (2)	23322 (2)	23272 (2)	23283 (2)	23283 (2)
551	CAPSCREW	25346 (10)	25346 (42)	25346 (42)	25346 (42)	25346 (42)	25346 (42)	25346 (10)	25346 (42)
553	LOCKWASHER 5/8	25359 (26)	25359 (42)	25359 (42)	25359 (42)	25359 (42)	25359 (42)	25359 (26)	25359 (42)
555	CAPSCREW	26258 (16)	N/A	N/A	N/A	N/A	N/A	26258 (16)	N/A
556	TIE BAR	23279 (2)	23280 (2)	23325 (2)	23326 (2)	23323 (2)	23349 (2)	23325 (2)	23325 (2)
700	BRAKE HOUSING	23348 (1)	23254 (1)	23254 (1)	23254 (1)	23254 (1)	23348 (1)	23254 (1)	23254 (1)

# APPENDIX C

## BRAKE CODE

ITEM NO.	PART DESCRIPTION	- 3	- 4	- 5	- 6	- 7	- 8	- 9	- 10
		PART NUMBERS							
802	SHUTTLE	N/A	20849	20849	N/A	N/A	20849	20849	N/A
806	CIRCULATION VALVE	20456	20456	20456	20456	N/A	N/A	N/A	N/A
806	1/4-18 NPT PIPE PLUG	N/A	N/A	N/A	N/A	25031	25031	25031	25031
807	1/8-27 NPT PIPE PLUG	25040	N/A	N/A	25040	25040	N/A	N/A	25040
807	1/8-27 NPT PIPE ADAPTOR	N/A	25622	25622	N/A	N/A	25622	25622	N/A
809	1/8 NPT CAPLUG	N/A	25374	25374	N/A	N/A	25374	25374	N/A
929	3/8-18 NPT PIPE PLUG	25085	25085	25085	25085	N/A	N/A	N/A	N/A
929	3/8 NPT CAPLUG	N/A	N/A	N/A	N/A	26276	26276	26276	26276
950	MOTOR SUB-ASSY	20504	22011	22012	20804	20505	21977	22013	20805

# APPENDIX D

ITEM NO.	PART DESCRIPTION	MODEL REDUCTION CODE			
		M30	M30A	M30D	M30F
		PART NUMBER			
300	FINAL PLANET HUB	23590	23243	23243	23784
320	FINAL PLANET GEAR	23587	20405	20405	23785
400	PRIMARY PLANET HUB	23589	20546	23172	23539
420	PRIMARY PLANET GEAR	23588	20545	23245	23540
430	PRIMARY INTERNAL GEAR	23541	20411	20411	23541
440	PRIMARY SUN GEAR	23603	20547	23174	23782

# BOLT TORQUE CHART

BOLT DIAMETER Inches	TORQUE Lb-ft	TORQUE Nm
1/4	9	12
5/16	18	24
3/8	32	43
7/16	50	68
1/2	75	102
9/16	110	149
5/8	150	203
3/4	265	359
7/8	420	569
1	640	868
1 1/8	800	1085
1 1/4	1000	1356
1 3/8	1200	1627
1 1/2	1500	2034

**NOTE:** Unless otherwise specified, torque bolts per above chart.

