

INSTRUCTION AND PARTS MANUAL
MODEL R7
PLANETARY HYDRAULIC WINCH

 **PULL MASTER**

A  **DOVER** COMPANY

THE LOGICAL CHOICE



READ THIS MANUAL BEFORE INSTALLING, OPERATING OR SERVICING THIS PRODUCT. THIS MANUAL CONTAINS IMPORTANT INFORMATION. MAKE THIS MANUAL AVAILABLE TO ALL PERSONS RESPONSIBLE FOR THE OPERATION, INSTALLATION, SERVICING AND MAINTENANCE OF THIS PRODUCT.

Pullmaster Limited Warranty

Effective 8/1/2008
SUPERSEDES ALL PRIOR WARRANTIES

Seller warrants that each article (whether Gear Drive Products, Brake Products and/or Winch Products, all of which are covered hereunder) sold under this order shall at the time of shipment (i) conform to applicable specifications, and (ii) be free from defects in material and workmanship during normal and ordinary use and service (the "Warranty").

Buyer's exclusive remedy and Seller's sole obligation under this Warranty shall be, at Seller's option, to repair or replace any article or part thereof which has proven to be defective, or to refund the purchase price of such article or part thereof. Buyer acknowledges that Buyer is knowledgeable concerning the articles covered by this Warranty and sold in connection therewith which are being purchased, that Buyer has reviewed this Warranty and that the remedies provided hereunder are adequate and acceptable to Buyer.

This Warranty shall expire one (1) year from the date the article is first shipped by Seller. Notice of claimed breach of this Warranty must be given by Buyer to Seller within the applicable period. Such notice shall include an explanation of the claimed warranty defect and proof of date of purchase of the article or part thereof for which warranty coverage is sought. No allowances shall be made by Seller for any transportation, labor charges, parts, "in and out" costs, adjustments or repairs, or any other work, unless such items are authorized in writing and in advance by Seller. Nor shall Seller have any obligation to repair or replace items which by their nature are expendable.

If an article is claimed to be defective in material or workmanship, or not to conform to the applicable specifications, Seller will either examine the article at Buyer's site or issue shipping instructions for return to Seller. This Warranty shall not extend to any articles or parts thereof which have been installed, used, or serviced otherwise than in conformity with Seller's applicable specifications, manuals, bulletins, or instructions, or which shall have been subjected to improper installation, operation, or usage, misapplication, neglect, incorrect installation, overloading, or employment for other than normal and ordinary use and service. This Warranty shall not apply to any article which has been repaired, altered or disassembled, or assembled by personnel other than those of Seller. This Warranty shall not apply to any article upon which repairs or alterations have been made (unless authorized in writing and in advance by Seller). This Warranty shall not apply to any articles or parts thereof furnished by Seller to Buyer's specifications and/or furnished by Buyer or acquired from others at Buyer's request.

SELLER MAKES NO EXPRESS WARRANTIES AND NO IMPLIED WARRANTIES OF ANY KIND, OTHER THAN THE WARRANTY EXPRESSLY SET FORTH ABOVE. SUCH WARRANTY IS EXCLUSIVE AND IS MADE AND ACCEPTED IN LIEU OF ANY AND ALL OTHER WARRANTIES, EXPRESS OR IMPLIED, INCLUDING WITHOUT LIMITATION THE IMPLIED WARRANTIES OF MERCHANTABILITY AND FITNESS FOR A PARTICULAR PURPOSE.

Buyer expressly agrees that Seller is not responsible to perform any work or investigation related in any way to tensional vibration issues and is not responsible for the detection or remedy of Natural Frequency Vibration of the mechanical system in which the unit is installed. Buyer acknowledges, understands and agrees that this Warranty does not cover failures of the unit which result in any manner from the operation of the machine or unit at vibration frequencies at or near the natural frequency vibration of the machine in such a way that damage may result. Buyer expressly agrees that Seller is not responsible for failure damage or accelerated wear caused by machine or ambient vibration. Further, Buyer acknowledges and agrees that Buyer is always solely responsible for determination and final approval of the "application factor" which may be used in Seller's calculations, and this application factor is 1.0 unless otherwise stated in Seller's quotation specifications.

The remedies for this Warranty shall be only those expressly set forth above, to the exclusion of any and all other remedies of whatsoever kind. The limited remedies set forth above shall be deemed exclusive, even though they may fail their essential purpose. No agreement varying or extending the foregoing Warranty, remedies, exclusions, or limitations shall be effective unless in a writing signed by an executive officer of Seller and Buyer. This Warranty is non-transferable. If a party who had purchased articles from Buyer, or from persons in privity with Buyer, brings any action or proceeding against Seller for remedies other than those set forth in this Warranty, Buyer agrees to defend Seller against the claims asserted in such action or proceeding at Buyer's expense, including the payment of attorneys' fees and costs, and indemnify Seller and hold Seller harmless of, from and against all such claims, actions, proceedings or judgments therein. Buyer also agrees to defend and indemnify Seller of, from and against any loss, cost, damage, claim, debt or expenses, including attorneys' fees, resulting from any claims by Buyer or third parties to property or injury to persons resulting from faulty installation, repair or modification of the article and misuse or negligent operation or use of the article, whether or not such damage to property or injury to persons may be caused by defective material, workmanship, or construction. **ADVISORY:** *Winches and hoists are not approved for lifting or handling personnel or persons unless specifically approved in writing from Seller for the specific intended application.*

Under no circumstances shall Seller be liable (i) for any damage or loss to any property other than the warranted article or part thereof, or (ii) for any special, indirect, incidental, or consequential damage or loss, even though such expenses, damages, or losses may be foreseeable.

The foregoing limitations on Seller's liability in the event of breach of warranty shall also be the absolute limit of Seller's liability in the event of Seller's negligence in manufacture, installation, or otherwise, with regard to the articles covered by this Warranty, and at the expiration of the Warranty period as above stated, all such liabilities shall terminate. Buyer's purchase of any article(s) covered by this Warranty shall constitute acceptance of the terms and conditions hereof and shall be binding upon Buyer and Buyer's representatives, heirs and assigns. The laws of the Province of British Columbia shall govern Buyer's rights and responsibilities in regard to this Warranty and the transaction(s) subject thereto, and the Province of British Columbia shall be the exclusive forum and jurisdiction for any action or proceedings brought by Buyer in connection herewith or any dispute hereunder. If any of the terms and conditions contained within this Warranty are void, the remaining provisions thereof are and shall remain valid and enforceable.

Note: *Prices and specifications contained in this price book are subject to change without notice.*

SAFETY RECOMMENDATIONS



DANGER

FAILURE TO COMPLY WITH THE FOLLOWING SAFETY RECOMMENDATIONS AND LOCAL RULES AND REGULATIONS WILL RESULT IN PROPERTY DAMAGE, SEVERE INJURY OR DEATH.



Definition: **Caution** indicates a potentially hazardous situation which, if not avoided may result in minor or moderate injury.



Definition: **Warning** indicates a potentially hazardous situation which, if not avoided could result in death or serious injury.



Definition: **Danger** indicates a potentially hazardous situation which, if not avoided will result in death or serious injury.

The planetary hydraulic winches are made for hoisting and lowering loads and to be operated by trained and professional personnel. They are not designed for operations involving lifting or moving personnel. The winches are powered by hydraulic power. The ropes / cables for hoisting operations are not supplied by PULLMASTER. The winches are always assembled in an application, they do not function as an independent machine and it is not allowed to use them as such.

The winches are to be used within the specifications as listed in the manual under "SPECIFICATIONS". Other use as foreseen in the functional description of the hydraulic winch is not allowed without written permission from PULLMASTER.

1. Do not install, operate or service winch before reading and understanding manufacturer's instructions.
2. The winch described herein is not designed for operations involving lifting or moving personnel.
3. Do not lift or carry loads over people.
4. Do not exceed recommended operating pressure (psi) and operating volume (gpm).
5. Do not jerk the winch. Always smoothly accelerate and decelerate load.
6. Do not operate a damaged, noisy or malfunctioning winch.
7. Do not leave a load suspended for any extended period of time.
8. Never leave a suspended load unattended.
9. Winch should be maintained and operated by qualified personnel.
10. Inspect winch, rigging, mounting bolts and hoses before each shift.
11. Warm-up equipment before operating winch, particularly at low ambient temperatures.
12. Verify winch function by raising and lowering a full test load to a safe height before each shift.
13. Do not weld any part of the winch.
14. Verify gear lubrication and brake circulation supply and return before operating winch.
15. Be sure of equipment stability before operating winch.
16. Wear proper clothing to avoid entanglement in rotating machinery.
17. Always stand clear of the load.
18. Use only recommended hydraulic oil and gear lubricant.
19. Keep hydraulic system clean and free from contamination at all times.
20. Maintain winch and equipment in good operating condition. Perform scheduled maintenance regularly.
21. Keep hands clear when winding wire rope onto the winch drum.
22. Do not use the wire rope as a ground for welding.
23. Rig the winch carefully. Ensure that the wire rope is properly anchored to the correct cable anchor slot at the cable drum.
24. Do not lift a load with a twisted, kinked or damaged wire rope.
25. Consult wire rope manufacturer for size, type and maintenance of wire rope.
26. Maintain five wraps of wire rope on the cable drum at all times.
27. In case of a power failure or breakdown leading to an unexpected stop of the hydraulic power circuit, stand clear of the area and the load being hoisted, take the necessary precautions to prevent access to area where the load is halted.
28. The noise level of the winch is 83 dBA measured on a distance of 1.00 meter, 1.60 meters high. The measuring equipment used was: Realistic #42-3019.
29. Clean up any oil spillage immediately.
30. Wear proper clothing and personal protection equipment such as, footwear, safety goggles and a hard hat. Read manual first.



DESCRIPTION OF THE MODEL R7

GENERAL DESCRIPTION:

The PULLMASTER Model R7 is a planetary, hydraulic winch primarily intended for mobile or recovery adaptations. The winch has equal speed in both directions and a freespool feature which can be operated manually or hydraulically, depending on the option. The main components of this unit are:

- + hydraulic gear motor
- + multi-disc brake with static and dynamic function
- + primary planet reduction
- + secondary planet reduction
- + final planet reduction
- + brake housing
- + cable drum
- + final drive housing
- + freespool mechanism

FUNCTION IN FORWARD ROTATION (PULLING):

In forward rotation, or when the winch is pressurized for pulling, the output torque and rpm of the hydraulic motor are transmitted through the brake shaft and freespool coupling to the final sun gear. The planet gears are driven by the final sun gear and cause the planet hub to drive the cable drum at a reduction of 9.25:1. When a load is pulled, an over-running clutch which connects the motor drive shaft to the automatic brake assembly, permits free rotation of the sun gear, without effecting the brake. When the winch rotation is stopped, the load on the cable drum causes the over-running clutch to lock and the load is held safely by the disc brake.

FUNCTION IN REVERSE ROTATION (PAYING OUT):

In reverse rotation, or paying out of a load, hydraulic pressure from the reverse side of the hydraulic motor is channelled to the brake piston, causing the brake piston to release the multi-disc brake. The pressure required to release the brake is 400 - 600 psi (28 - 42 bar). The over-running clutch, connecting the motor drive shaft to the brake assembly, locks, causing the brake discs to rotate between stationary divider plates. If the load on the cable drum increases the pay out speed, the resulting pressure drop in the brake piston increases friction between the friction plates and slows the drum. In this way, a completely smooth pay out speed can be achieved in a stepless operation by modulation of the winch control valve. When the control valve is returned to neutral position, rotation stops and the disc brake applies automatically.

During pay out operations of the winch, the friction created by the brake discs results in heat. This heat is dissipated by the circulation of hydraulic fluid from the brake housing, supplied internally through the hydraulic motor. This circulation flow is internally vented to the return line through a check valve arrangement inside the specially modified motor. The circulation flow is supplied only when the wire rope is payed out. A separate vent line connecting the PULLMASTER Model R7 with the hydraulic reservoir is not required (see TYPICAL HYDRAULIC CIRCUIT).

IMPORTANT: SAFETY VALVE

The PULLMASTER Model R7 winch does not require a drain line up to 100 psi permissible back pressure in the brake housing. To indicate excessive pressure and potential damage to the hydraulic motor or to the oil seal in the brake housing, a safety valve is installed on the motor adaptor.

DESCRIPTION OF THE MODEL R7 CONTINUED

BREATHER RELIEF VALVE

Excessive pressure in the brake housing will damage the oil seal separating the brake housing from the drum interior. Damage to this seal will cause the drum to fill up with hydraulic fluid. To prevent damage to the drum seal and end cover of the final drive if the cable drum fills up with hydraulic fluid, a breather relief (PARTS REFERENCE item 130) is installed on the end cover. The breather relief does not prevent oil seal failure but serves as an indicator or warning that the seals between brake housing and the cable drum interior have failed and must be replaced immediately.

FUNCTION OF THE FREESPOOL MECHANISM:

MODEL R7-15-135-1M

This model has a manually actuated freespool function. The freespool feature is enabled by turning the freespool handle 180 degrees in a counterclockwise direction. This will disengage the final sun gear from the secondary planet hub and provide for a free turning drum. To re-engage the drum, turn the handle 180 degrees in a clockwise direction.

IMPORTANT: The freespool function cannot be engaged or disengaged under load or while the cable drum is rotating.

MODEL R7-15-135-1F

This model has a hydraulically actuated freespool feature. The final sun gear is pulled out of engagement with the secondary planet hub, by the freespool piston, which is spring applied and pressure released. To disengage the sun gear, hydraulic pressure of 400 psi (28 bar) must be supplied to the freespool release port (see INSTALLATION DRAWING). When the hydraulic pressure is removed, the sun gear will re-engage.

IMPORTANT: The freespool function cannot be engaged or disengaged under load or while the cable drum is rotating.

EXPLANATION OF MODEL CODING

All variations of the PULLMASTER Model R7 planetary winch are identified by the following code:

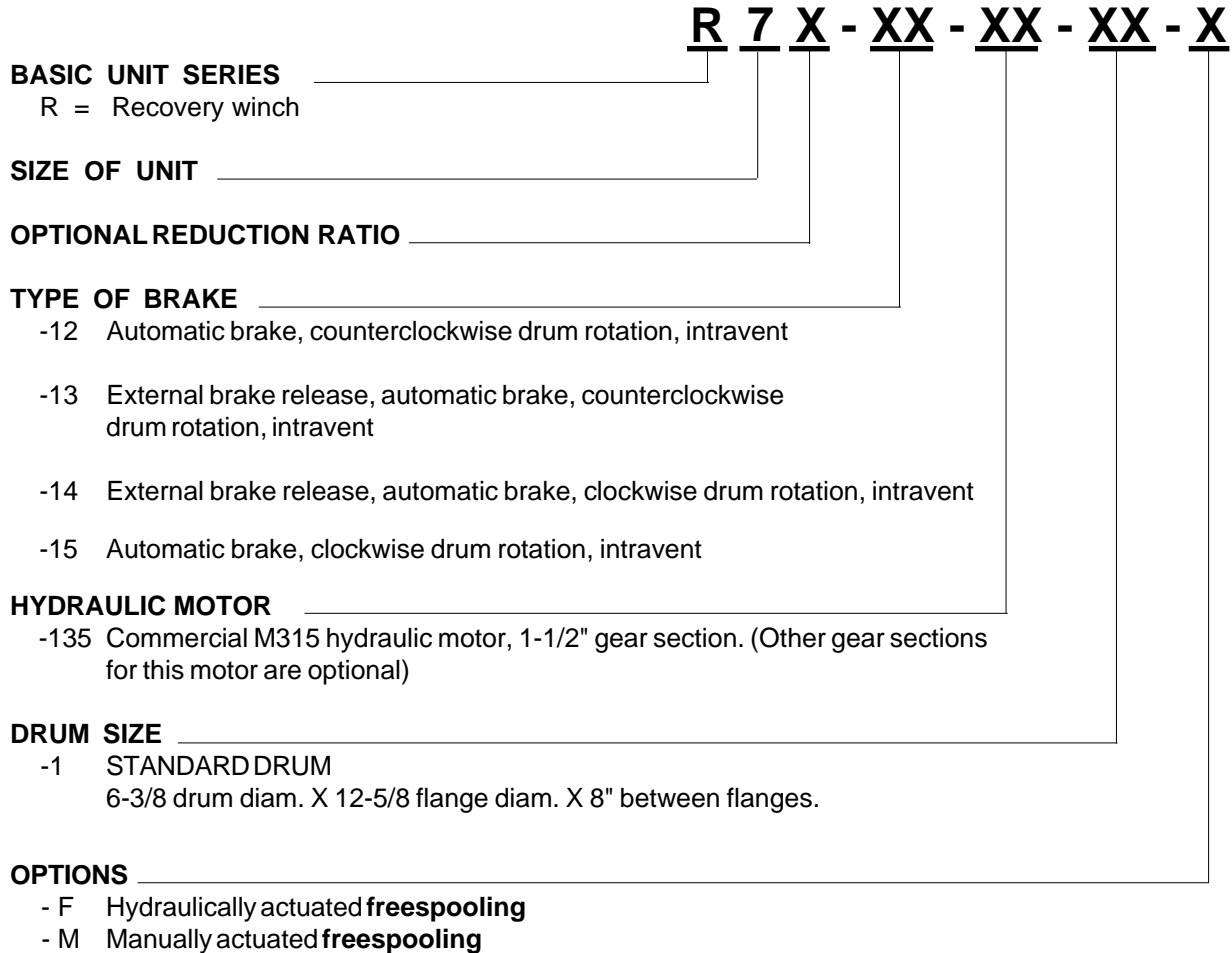

NOTE:

Options for drum grooving are identified by a spec. number.

Clockwise and counterclockwise drum rotation is the direction of rotation for pulling, established by looking at the hydraulic motor.

OPTIONS

CLOCKWISE ROTATION:

The drum rotation of the standard PULLMASTER Model R7 planetary winch is clockwise for pulling when looking at the hydraulic motor of the winch. Drum rotation for counter clockwise hoisting direction is available as an option.

OPTIONAL HYDRAULIC GEAR MOTOR:

The performance of the standard PULLMASTER Model R7 planetary winch is based on a *Commercial model M315* hydraulic motor with a displacement of 1.9 cubic inches. The performance of the winch can be changed by using motors with different displacements.

(Contact the factory for performance information if using motors with different displacements.)

The PULLMASTER WINCH CORPORATION will consider other options for quantity requirements.

SPECIFICATIONS

Performance specifications are based on standard hydraulic motor, gear ratio and cable drum with 5/8 inch diameter wire rope. Performance specifications for winches supplied with optional motors are provided in attached supplement.

CABLE DRUM DIMENSIONS (STANDARD DRUM):

Barrel diameter	6.38 in	162 mm
Flange diameter	12.63 in	321 mm
Barrel length	8.00 in	203 mm

CABLE STORAGE CAPACITY:

(Size of wire rope)	7/16 in	278 ft	85 m
	1/2 in	217 ft	66 m
	9/16 in	167 ft	51 m
	5/8 in	124 ft	38 m

MAXIMUM OPERATING PRESSURE: 2100 psi 145 bar

MAXIMUM OPERATING VOLUME: 18 (US) gpm 68 l/min

MINIMUM OPERATING VOLUME: 6 (US) gpm 23 l/min

DRUM TORQUE AT MAXIMUM PRESSURE: 54,000 lb-in 6,101 Nm

DRUM RPM AT MAXIMUM VOLUME: 15.5 rpm

LINE PULL AT MAXIMUM PRESSURE:

Bare drum	15,429 lb	68.6 kN
Full drum	9,000 lb	40.0 kN

LINE SPEED AT MAXIMUM VOLUME:

Bare drum	28 fpm	8.7 m/min
Full drum	49 fpm	15 m/min

PERMISSIBLE SYSTEM BACK PRESSURE AT MOTOR RETURN PORT:

100 psi 6.9 bar

LUBRICATING OIL: Volume: 0.8 (US) gal 3 liters

Refer to RECOMMENDATIONS for viscosity and instructions.

PERFORMANCE GRAPHS

PG-R7-A

LINE PULL VS. OIL PRESSURE:

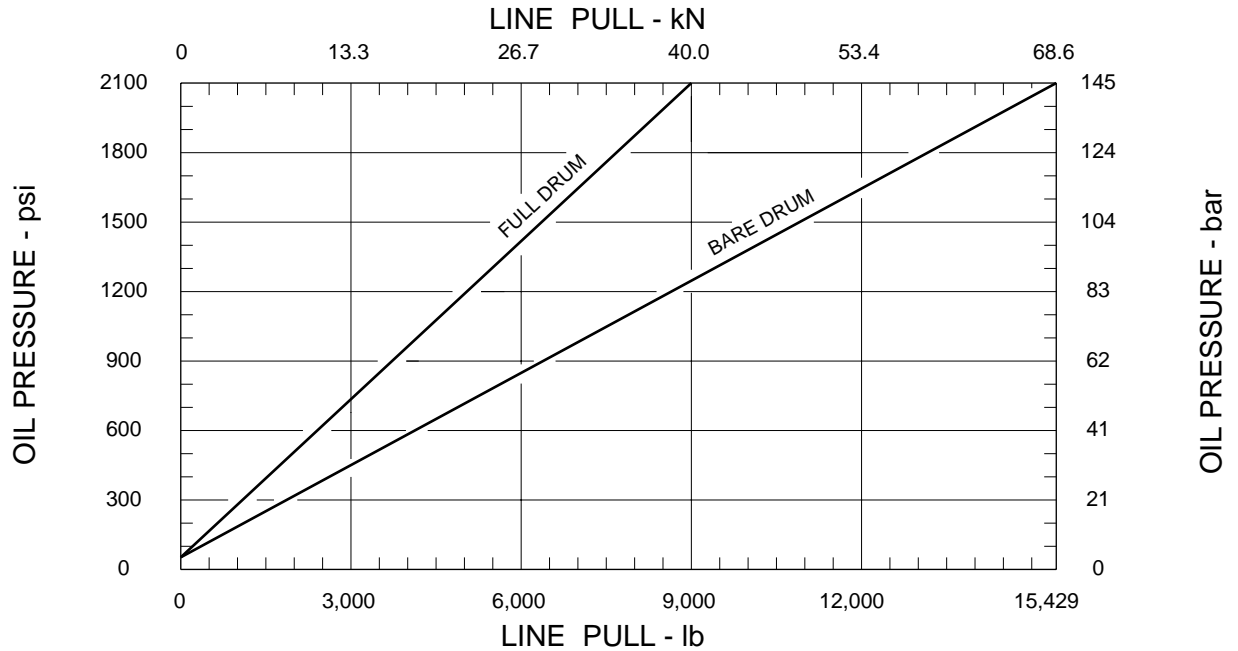

LINE SPEED VS. OIL VOLUME:

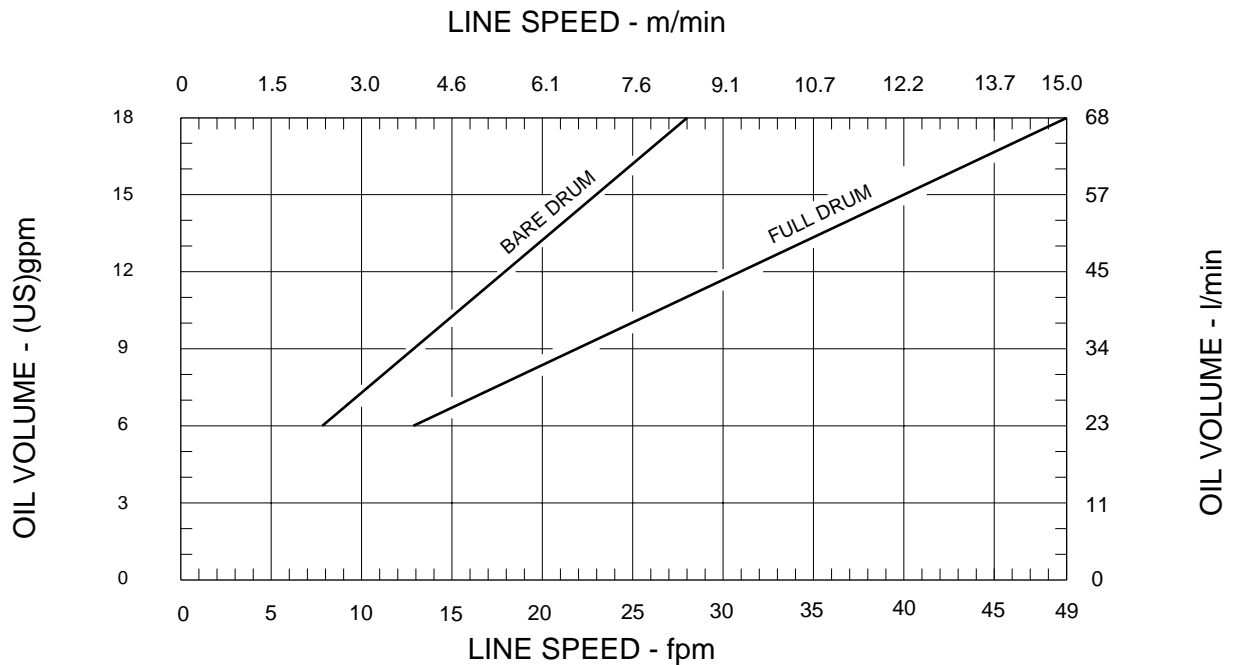

Performance graphs are based on standard hydraulic motor and cable drum with 5/8 inch diameter wire rope.

TYPICAL HYDRAULIC CIRCUIT (R7-M)

HC-R7-M-A

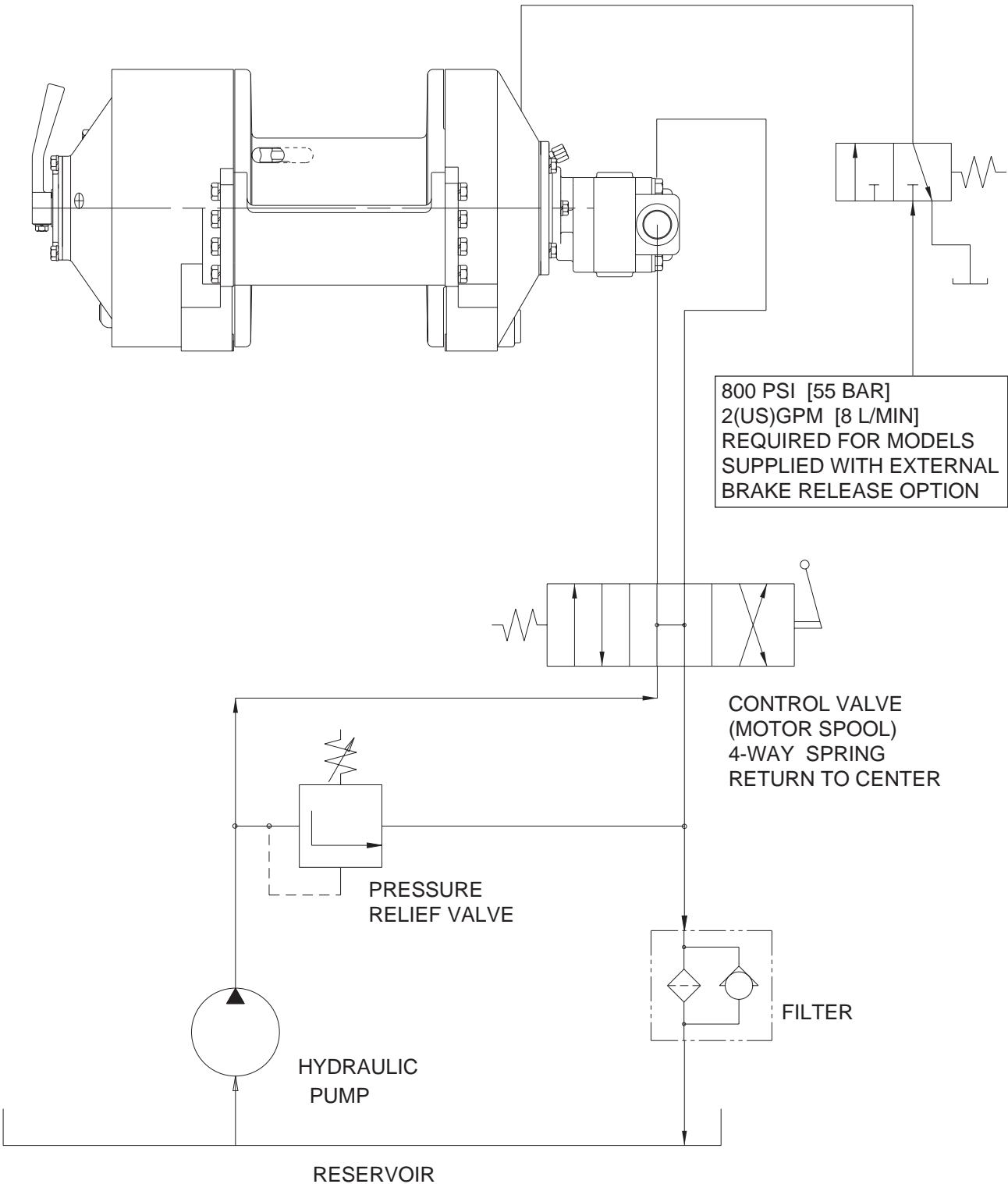

TYPICAL HYDRAULIC CIRCUIT (R7-F)

HC-R7-F-A

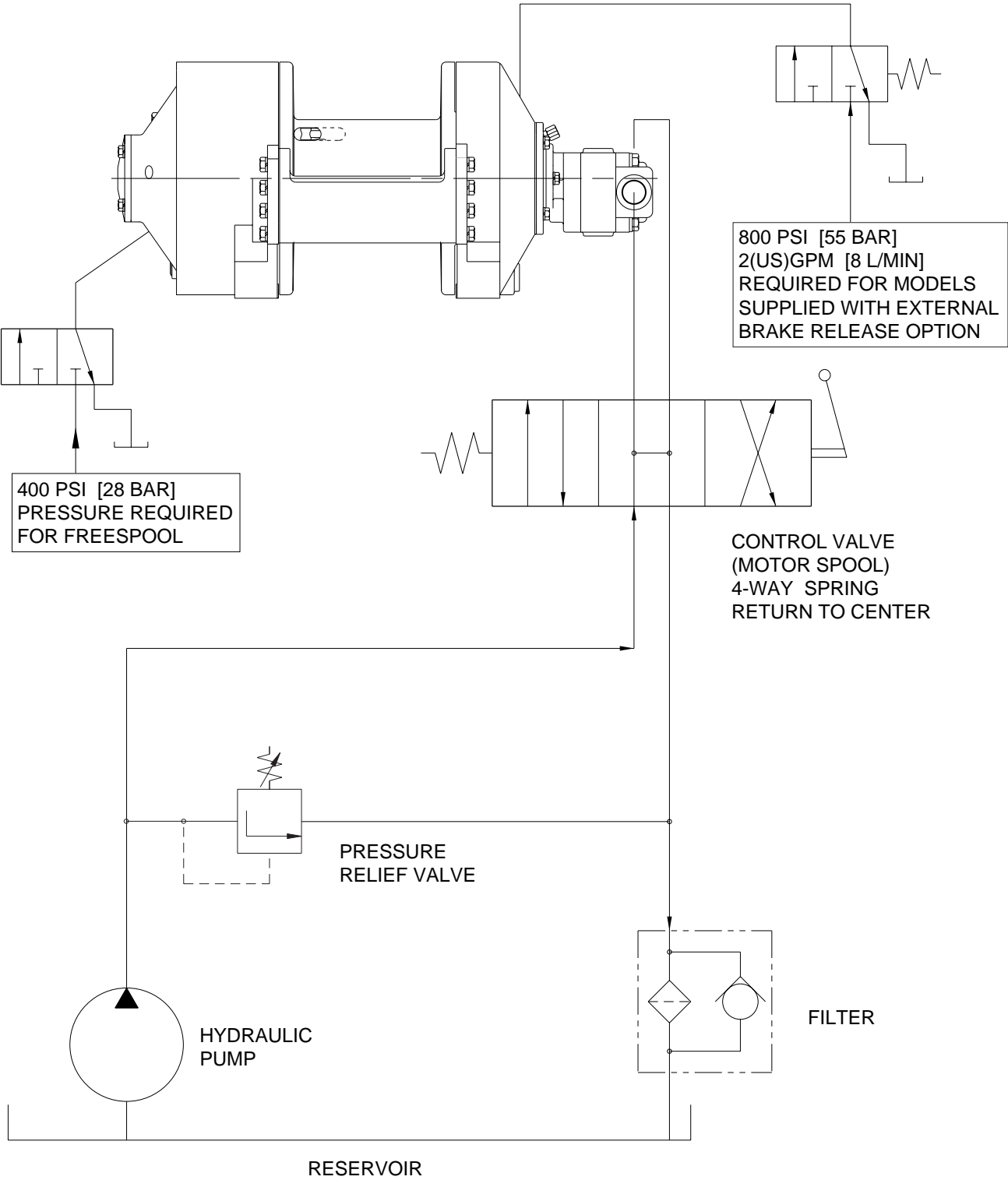

RECOMMENDATIONS

HYDRAULIC FLUID:

The hydraulic fluid selected for use with PULLMASTER planetary winches should be a high grade, petroleum based fluid, with rust, oxidation and wear resistance. Fluid cleanliness and operating viscosity are critical to winch reliability, efficiency and service life.

For optimum performance, the recommended viscosity range at operating temperature is 81 - 167 SUS (16 - 36 CS). For extreme operating conditions of short duration, the maximum viscosity range of 58 - 4635 SUS (10 - 1000 CS) should not be exceeded.

For optimum performance, the winch recommended hydraulic fluid temperature operating range is 80 - 150F (27 - 66 C). For extreme operating conditions of short duration, the maximum temperature range of -5 - 180F (-21 - 82 C) should not be exceeded.

LUBRICATION:

The winch gear train requires oil bath lubrication. The winch is shipped from the factory without lubricating oil.

IMPORTANT: ADD LUBRICATING OIL BEFORE RUNNING WINCH.

Refer to INSTALLATION DIMENSIONS for location of lubricating oil fill port. Refer to SPECIFICATIONS for quantity of oil required. For normal operating temperatures use SAE 90 lubricating oil. Consult lubricating oil supplier or factory for temperature beyond normal operating range.

HYDRAULIC PUMP:

For maximum performance of the PULLMASTER planetary winch, the hydraulic pump must supply the maximum flow of hydraulic fluid at the hydraulic pressure stated in SPECIFICATIONS.

HYDRAULIC CONTROL VALVE:

The standard control valve used for operation of the PULLMASTER planetary winch must have a four-way, spring return to neutral feature, which provides for open flow from the pressure ports of the winch to the reservoir in neutral position of the control (motor spool). It is important to point out that good speed control, especially when paying-in out a load, depends on the "metering" characteristics of the control valve. The better the oil flow is "metered" the better will be the speed control.

HYDRAULIC PRESSURE RELIEF:

The hydraulic circuit for the PULLMASTER planetary winch requires a pressure relief set at the operating pressure (see SPECIFICATIONS). Usually, a pressure relief is part of the hydraulic control valve. Where this is not the case, a separate pressure relief valve must be installed and set at the recommended maximum pressure.

HYDRAULIC RESERVOIR:

It is recommended that the hydraulic reservoir has sufficient capacity to provide good heat dissipation in order to prevent over-heating of the hydraulic fluid. The hydraulic reservoir should be made from clean and scale-free material to prevent contamination of the hydraulic fluid. In order to prevent air from being mixed with the hydraulic fluid, the reservoir should have an over-flow baffle separating the return lines from the suction line and all return lines should enter the reservoir below the fluid level. The reservoir should be mounted close to and above the hydraulic pump in a location which provides for free air circulation around the reservoir.

HYDRAULIC HOSES:

The following hydraulic hoses are recommended for maximum efficiency of the PULLMASTER Model R7 planetary winch:

Pressure lines:	Equivalent to SAE 100R12-12
Hydraulic freespool line:	Equivalent to SAE 100R3-3

It is recommended that a larger size of hydraulic hose is installed where the pressure lines or the circulation lines are excessively long.

HYDRAULIC FILTER:

Hydraulic filter recommendations for the hydraulic circuit of the PULLMASTER planetary winch, based on a return line filter, are given as follows:

Average atmosphere:	10 microns
Dusty atmosphere:	5 microns

In order to prevent accidental stoppage of the return line flow, the oil filter should have a by-pass feature.

USE OF AN E STOP:

The use of an E stop (emergency) is mandatory in the controls circuit, the E stop is to be placed in the operators control panel. The E stop has to be designed and placed in line with EN 60204 and EN 418.

INSTALLATION INSTRUCTIONS



DANGER

**FAILURE TO FOLLOW INSTALLATION INSTRUCTIONS COULD
RESULT IN PROPERTY DAMAGE, SEVERE INJURY OR DEATH.**

The initial installation or mounting of a PULLMASTER planetary winch is critically important for proper operation and performance. If the winch is mounted to an uneven surface, the centre line of the unit can be distorted to a point where the winch will not operate in either direction. It is therefore very important that the following instructions are observed when a PULLMASTER planetary winch is installed:

- 1) Make certain that the mounting platform is sufficiently strong in order to avoid deflection when a load is lifted.
- 2) Set the winch on the mounting platform and check for surface contact on all mounting pads of the winch.
- 3) If there is a space between the mounting surface and one of the mounting pads, the mounting surface is not even and the space below the mounting pad must be shimmed. If this condition exists, proceed as follows:
 - a) Install mounting bolts snug tight on the three mounting pads which are in contact with the mounting surface. (For mounting bolt size and grade see INSTALLATION DIMENSIONS.)
 - b) Measure the space underneath the fourth mounting pad with a feeler gauge and use shim stock of equivalent thickness in the space between the mounting pad and the mounting surface.
 - c) Only after this procedure should the fourth mounting bolt be installed. Tighten all four bolts per BOLT TORQUE CHART.
- 4) Fill the winch with lubricating oil. (See SPECIFICATIONS for oil volume required.)
- 5) Use recommended circuit components and hydraulic hoses.
- 6) Verify that breather relief, item 130, is in place on end cover above oil level. End cover may need to be rotated if winch is not installed upright.

IMPORTANT:

Do not replace breather relief or safety valve with a pipe plug. The breather relief does not prevent oil seal failure but serves as an indicator or warning that the oil seals between brake housing and the cable drum interior have failed and must be replaced immediately. The safety valve acts as a warning that excessive pressure is present in the brake housing and must be rectified immediately.

- 7) The circulation return line of the winch should be plumbed in such a manner that the brake housing remains filled with oil at all times. Connect the return line directly to reservoir. Do not connect to a common return line.

OPERATING INSTRUCTIONS



DANGER

**FAILURE TO FOLLOW OPERATING INSTRUCTIONS COULD
RESULT IN PROPERTY DAMAGE, SEVERE INJURY OR DEATH.**

After the PULLMASTER planetary winch has been installed in accordance with the INSTALLATION INSTRUCTIONS, the wire rope can be fastened to the cable drum.

IMPORTANT: The ropes, chains, slings, etc. are not part of the winch and are not covered by this manual. Refer to manufacturer's handling, inspection and maintenance recommendations to avoid potential accidents. For selection of ropes, etc. please check following product standards: DIN 15020, prEN818-1/9, prEN 1492-1/2, prEN 1677-1/3 and other relevant product standards.

- 1) The cable drum of the PULLMASTER planetary winch has two cable anchor slots, one for clockwise and one for counterclockwise pulling. Standard rotation for pulling is clockwise when looking at the hydraulic motor of the unit. It is critical to select the cable anchor slot which will permit winding of the wire rope on the drum in the correct direction of rotation. If the wire rope is wound on the cable drum in the wrong direction of rotation, the winch will have no braking capacity. Each winch is shipped from the factory with a label on the drum indicating the correct cable anchor slot.

SI1013-R7

WIRE ROPE INSTALLATION

Clockwise pulling winch shown. (Use cable anchor slot on opposite side of drum for counterclockwise pulling winch.)

Feed the wire rope through the cable anchor slot. Loop rope back into slot as shown. Insert cable anchor into slot, small end first and long side nearest the drum flange. Pull rope tight to wedge rope in slot.

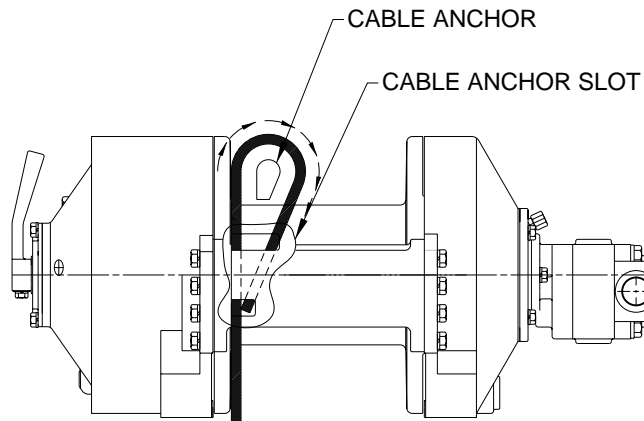

- 2) On wire rope installation, care must be taken that the wire rope is wrapped completely around the cable anchor and properly pulled into the cable anchor slot in the cable drum. The cable drum requires 5 wraps of wire rope for safety.
- 3) The winch operation is controlled by a single control valve lever which has a **forward**, a **reverse** and a **neutral** position. Speed control in either direction is obtained by modulation of the control valve lever. Maximum line speed in either direction is obtained when the control valve lever is moved as far as it can go. The disc brake of the winch will come on automatically when the winch control lever is returned to **neutral**.
- 4) Always warm up equipment prior to operating winch, particularly in low ambient temperature. Circulate hydraulic oil through the winch control valve for several minutes to warm the hydraulic system. To prime the winch with warm oil, operate the winch at slow speed, forward and reverse, several times.
- 5) Prevent corrosion damage to winch interior. If not used regularly, run winch up and down at least once every two weeks.
- 6) To ensure proper winch installation and function, raise and lower a full test load to a safe height before using winch for regular operation at the start of each shift.

If, after a new installation, the winch does not function properly, refer to the TROUBLESHOOTING section of this manual.

TROUBLE SHOOTING

GENERAL:

In most cases, when the hydraulic winch does not perform satisfactorily, the cause of malfunction is found somewhere in the hydraulic circuit. Before the winch is removed from its mounting and disassembled, all of the hydraulic circuit components should be checked for proper function.

IMPORTANT:

The hydraulic oil volume relates to the line speed or rpm of the winch.

Therefore, if the winch does not produce the maximum rated line speed, a loss of hydraulic flow somewhere in the hydraulic circuit system can be analysed. If this condition exists, install a flow meter into the hydraulic circuit to check the volume supplied to the motor ports when the winch control is completely opened. The flow meter should indicate the maximum operating volume. If the test described indicates a loss of hydraulic flow, check the hydraulic pump, the relief valve and the control valve.

The hydraulic pressure relates to the line pull or lifting capacity of the winch.

If the winch will not pull the maximum rated load, install a pressure gauge into the pressure line leading to the pulling port on the hydraulic winch motor. Stall the winch to prevent rotation of the drum and then open the control valve and check the hydraulic pressure reading of the installed pressure gauge. If the pressure reads below the specified maximum operating pressure, look for trouble in the hydraulic pump, the relief valve and the control valve. When checking oil pressure or oil volume anywhere in the hydraulic system, make certain that the hydraulic pump is running at maximum operating rpm. Installations using a belt drive for hydraulic pump must be checked for belt slippage. Verify that hydraulic reservoir is filled to the top level.

Only if the hydraulic system has been checked and found to be in order, use the following indications for probable causes of failure in the winch:

FAILURE	PROBABLE CAUSE
Winch will not produce line pull at maximum pressure as listed in SPECIFICATIONS.	<ul style="list-style-type: none"> a) Winch is mounted to an uneven surface (see INSTALLATION INSTRUCTIONS). b) Cable sheaves or block purchase operated with the winch are not turning freely. c) Damage or wear in the hydraulic motor. d) Excessive back pressure in the hydraulic system. e) Relief valve may be set too low.
Winch will not produce line speed at maximum volume as listed in SPECIFICATIONS.	<ul style="list-style-type: none"> a) Winch is mounted to an uneven surface (see INSTALLATION INSTRUCTIONS). b) Cable sheaves or block purchase operated with the winch are not turning freely. c) Damage or wear in the hydraulic motor d) Excessive back pressure in the hydraulic circuit.
Winch will not reverse.	<ul style="list-style-type: none"> a) Leakage out of the brake piston prevents the brake from being released against the brake springs. This is caused by damaged O-ring seals on the brake piston. b) The O-ring seals, on the brake release channel between the motor adaptor and the brake housing is damaged. If this failure occurs there will be substantial leakage from between the motor adaptor and brake housing. c) Insufficient hydraulic pressure (see SPECIFICATIONS for minimum operating pressure). d) Winch is mounted to an uneven surface (see INSTALLATION INSTRUCTIONS). e) Hydraulic pressure is not reaching the brake piston (plugged brake release orifice in the brake housing).

TROUBLE SHOOTING

FAILURE	PROBABLE CAUSE
Brake will not hold	<ul style="list-style-type: none"> a) Brake plates or divider plates have been damaged by contamination in the hydraulic fluid, or lack of circulation flow in the brake housing. b) Brake piston is seized in the brake housing because of contamination in the hydraulic fluid. c) Excessive back pressure in the return line causes the brake to be released. Back pressure in the circuit return line should be held below 100 psi (7 bar). d) Control valve has incorrect spool, which traps hydraulic pressure in the brake piston when the control valve handle is returned to neutral position. For proper function of the automatic brake, both pressure ports of the winch must be open to the reservoir in neutral position of the control valve. e) Wire rope is fastened to the incorrect cable anchor slot. f) The over-running clutch, which connects the motor shaft with the brake assembly, is damaged. g) Winch supplied with external brake release is not plumbed per HYDRAULIC CIRCUIT. Failure to vent external brake release port to reservoir may trap pressure and cause winch brake to slip.
Brake vibrates when lowering a load	<ul style="list-style-type: none"> a) Pump is too slow. Pump rpm must be maintained at normal operating speed when a load is lowered. b) Brake is running too hot. This is caused by a complete lack of, or insufficient circulation flow. To check the circulation, observe the flow of oil from the circulation return line of the winch (approx. 3.5 (US) gpm - 13 l/min when the winch is reversed). c) Control valve has poor metering characteristics. d) Damaged brake plates or divider plates. e) Air mixed with hydraulic oil (foamy oil).
Cable drum will not freespool	<ul style="list-style-type: none"> a) Insufficient pressure to disengage freespool shaft. Check with a pressure gauge to verify that 400 psi (28 bar) is being supplied to the freespool release port. b) If pressure is being lost at the freespool release port, then the o-ring that seals the freespool piston, item 265, has been damaged. c) The freespool piston may have become seized, due to foreign material in the hydraulic fluid. d) There is a load on the drum, or the drum is turning. The drum must be stopped and there can be no load on the wire rope, while the freespool option is used.
Oil leaks	<ul style="list-style-type: none"> a) Oil leaks from the hydraulic motor flange and the motor adaptor are caused by damaged O-ring seals. b) Oil leaks occurring between the cable drum flanges and housings are caused by excessive pressure in the brake housing. Excessive pressure will damage the oil seal which separates the brake housing from the cable drum interior. c) If the breather relief on the end cover leaks, the seal between the drum interior and the brake housing is damaged and must be replaced. This condition is caused by excessive pressure in the brake housing of the winch, operation with the incorrect hydraulic fluid during cold weather, or a restriction in the circulation return line leading back to tank.

Refer to the SERVICE INSTRUCTIONS if it becomes necessary to disassemble the Model R7 winch.

SERVICE INSTRUCTIONS

GENERAL:

Before attempting disassembly of the PULLMASTER Model R7 planetary winch with freespool, the following instructions should be read and understood.

It is suggested that all expendable parts such as o-rings and oil seals are not reused on reassembly. It is therefore important to have a seal kit, part no. 26035, on hand before the unit is taken apart.

A clean working area is of prime importance, similar to conditions used for service work on any other hydraulic component. All parts, as they are removed from the winch assembly, should be carefully inspected for wear and damage and be thoroughly cleaned before installation.

During reassembly, lubricate all o-rings and oil seals with grease before installation.

In the following service instructions, reference to parts is made by part description and reference number, which you will find in one of the three parts lists and associated group drawings.

DISASSEMBLY

FOR THE MAJORITY OF REQUIRED SERVICE OR REPAIR WORK, DISASSEMBLY IS REQUIRED ONLY ON THE BRAKE HOUSING ASSEMBLY OF THE PULLMASTER MODEL R7 PLANETERY WINCH. There are no special tools needed for the service and repair work and no adjustments or calibrations are necessary. Proceed with the disassembly as follows:

REMOVE HYDRAULIC MOTOR ASSEMBLY:

- 1) Remove two capscrews, item 815, together with lockwashers, item 817, which attach the motor to the motor adaptor, item 800. The hydraulic motor, item 850, can now be pulled out of the winch assembly.
- 2) Remove and discard o-ring, item 811.
- 3) Remove the connecting tube, item 830, and discard o-rings, item 831, from both ends of the connecting tube.
- 4) The standard motor of the Model R7 is a Commercial M315 hydraulic gear motor with a 1-1/2" gear section. If a problem is analysed to be in the hydraulic motor, we recommend that a COMMERCIAL INTERTECH dealer be contacted for parts and service. Normally, a problem in the hydraulic motor occurs in the gear section.

If the hydraulic motor is disassembled, the original flange section of the motor must be re-used in order to provide the required porting for the operation of the automatic brake, and for the circulation flow.

REMOVE BRAKE ASSEMBLY:

- 1) Remove the four capscrews, item 821, and lockwashers, item 823, from the motor adaptor, item 800. The motor adaptor can now be taken from the brake housing assembly, and o-ring, item 707, discarded.

NOTE: Since the brake springs, item 752, apply pressure against the inside of the motor adaptor, it is recommended that the hex capscrews are unscrewed one turn at a time until the spring pressure has been released.

- 2) After the hydraulic motor assembly has been removed, all parts of the brake assembly are accesible. Remove the 6 brake springs, item 752.
- 3) Pull the brake piston, item 750, out of the brake housing. Discard o-rings, item 751 and item 753. Remove pipe plug, item 757, and make certain that the hole of the orifice plug, item 754, is clear and unobstructed by debris and contamination. Re-install pipe plug, item 757.
Check the brake piston outside diameters and the inside diameters of the brake housing for surface scratches due to particles in the hydraulic fluid (contamination). If there is any evidence of surface damage, polish with fine emery cloth.
- 4) Pull the motor drive shaft, item 730, out of the brake housing together with hub assembly. Remove the brake hub assembly by taking off circlip, item 727. Remove the 2 sprag clutch aligners, items 722 and 724, from both

SERVICE INSTRUCTIONS CONTINUED

sides of the brake hub, item 720, and inspect for wear. Carefully remove the sprag clutch, item 723, and inspect for damage. Inspect the surfaces of the motor drive shaft and the brake hub, where the sprag clutch engages. If these surfaces show any deep indentations or surface damage, they should be replaced.

- 5) Remove the 7 divider plates, item 713, and the 6 brake plates, item 716. Inspect these parts for wear or damage and replace if necessary.
- 6) Remove brake spacer, item 712, two thrust washers, item 737, and thrust bearing, item 739.
- 7) The oil seal, item 711, along with backup washer, item 710, which seals the brake housing from the cable drum interior, can now be removed and discarded

All parts have now been removed from the brake housing, and there is no need for further disassembly, unless a failure has been analysed in the remaining winch assembly.

REASSEMBLY OF BRAKE HOUSING ASSEMBLY:

Unless otherwise specified, use torque chart at back of manual.

- 1) Clean all parts thoroughly before reassembly and apply grease liberally to all o-rings and oil seals. Use only new o-rings and oil seals (Seal kit for winch assembly, part no. 26035).
- 2) Install new backup washer, item 710, and new well lubricated oil seal, item 711, in the bore of the brake housing.
- 3) Install thrust bearing, item 739, with a thrust washer, item 737, on each side, into the brake hub.
- 4) Install the sprag clutch, item 723, in the bore of the brake hub, item 720. Insert the sprag clutch aligner, item 722, into one side of the brake hub. Insert the other sprag clutch aligner, item 724, into the other side of the brake hub. Carefully slide the motor drive shaft, item 730, through the sprag clutch aligner, item 724, into the brake hub assembly and fasten into place by installing circlip, item 727.

IMPORTANT: For the -14 and -15 brake configurations the sprag clutch must be installed in such a manner that the motor end of the motor drive shaft turns free in clockwise rotation and locks up in counter clockwise rotation. For the -12 and -13 brake configurations, the rotation is opposite to the above procedure.

- 5) Insert the externally splined end of the motor drive shaft, together with the brake hub assembly, into the brake housing and rotate it until it engages into the spline of the primary sun gear, item 440.
- 6) Insert brake spacer, item 712, so that the flat side face out towards you, and install a divider plate, item 713, against it. Then, starting with a brake plate, item 716, alternate the 6 brake plates with the remaining 6 divider plates. The brake stack must finish with a divider plate.
- 7) Install well greased o-rings, item 751 and 753, onto the brake piston, item 750. Carefully insert the brake piston into the brake housing and turn the piston to line up the bore for the connecting tube, item 830, with the bore in the motor adaptor, item 800. Install the six brake springs, item 752.
- 8) Check the safety valve, item 840, on the motor adaptor for proper sealing. Install new, well greased o-ring, item 707, on the flange of the motor adaptor, and fasten this part to the brake housing by using four hex head capscrews, item 821, and lockwashers, item 823. These screws should be tightened evenly, one turn at a time, against the pressure exerted by the brake springs.

IMPORTANT: For the -14 and -15 brake configurations, the motor adaptor must be reassembled with the mounting holes for the hydraulic motor in a parallel position to the mounting surface of the winch, and the bore for the connecting tube on the right side. For the -12 and -13 brake configurations, the bore for the connecting tube is located on the left hand side.

- 9) Install new o-rings, item 831, on each end of the connecting tube, item 830, and apply grease liberally. Insert the long end of the connecting tube into the motor adaptor.
- 10) Install new, well greased o-ring, item 811, on the flange of the hydraulic motor and fasten the motor by using two hex head capscrews, item 815, and lockwashers, item 817.

SERVICE INSTRUCTIONS CONTINUED

The Pullmaster Winch is now reassembled and ready for installation.

DISASSEMBLY OF FINAL DRIVE ASSEMBLY:

If a failure occurs in the mechanism located inside the final drive housing, or the winch has to be disassembled beyond the point described in the preceding chapter, proceed as follows:

- 1) Remove the drain plug, item 121, from the freespool cover, item 250, and drain the lubricating oil from the final drive assembly and the cable drum interior. In order to drain all of the oil out of the cable drum interior, the winch should be tipped to an angle, and the filler plug, item 503 removed.
- 2) After draining all lubricating oil from the final drive housing, item 100, remove internal retaining ring, item 124, and knock spring pin, item 259, up into the hole in the final drive housing, for clearance. The freespool assembly along with the final sun gear can now be pulled out of the final drive housing and put aside. If a problem exists in the freespool assembly, skip ahead to the section titled DISASSEMBLY OF FREESPOOL ASSEMBLY.
- 3) Pull out the final planet hub assembly and inspect for wear or damage. If the final planet hub gears, item 320, have to be removed, take off circlip, item 311, from planet pin, item 310, and press the planet pin out of the final planet hub, item 300. Remove the final planet gear, item 320, together with loose rollers, item 323, and thrust washers, item 321. NOTE: On reassembly these thrust washers must be installed.

All parts have now been removed from the final drive assembly. If further disassembly is required, proceed as follows:

DISASSEMBLY OF CABLE DRUM ASSEMBLY:

If a problem is analysed to be in the primary or secondary reductions, the cable drum assembly must be disassembled. After draining lubrication oil, proceed as follows:

- 1) Remove 16 hex head capscrews, item 555, along with lockwashers, item 553, from the final housing, item 100, and the brake housing, item 700, and remove the two tie bars, item 556 and 558.
- 2) The brake housing, item 700, can now be pulled out of the cable drum, item 500. The cylindrical roller bearing, item 509, comes apart with the outer race remaining in the cable drum, and the rest stays on the hub of the brake housing. Remove and discard oil seal, item 515, and inspect nylon spacer, item 704, for wear. Replace spacer if less than 7/32" thick.
- 3) Pull the primary planet hub assembly out of the cable drum. Check nylon spacer, item 402, for wear and replace if less than 7/32" thick.
- 4) If the primary planet gears, item 420, have to be removed, first remove primary sun gear, item 440, and sun gear stopper, item 494, from the primary planet hub assembly. Take off circlip, item 411, from planet pin, item 410, and press the planet pin out of the primary planet hub, item 400. Remove the primary planet gear, item 420, together with needle bearings, item 423, and thrust washers, item 421.

NOTE: On reassembly these thrust washers must be re-installed. Also, ensure that the secondary sun gear, item 490, with circlip, item 491, are in place before planet gears are re-installed.

- 5) The secondary planet hub assembly can now be pulled out of the cable drum. Inspect the planet hub stopper, item 453, for wear and replace if less than 5/16" thick.
- 6) Inspect the internal splines of the secondary planet hub for excessive wear or broken teeth, and replace if necessary. If the secondary planet gears, item 470, have to be removed, take off circlip, item 461, from planet pin, item 460, and press the planet pin out of the primary planet hub, item 450. Remove the primary planet gear, item 470, together with loose rollers, item 473, and thrust washers, item 471. NOTE: On reassembly, these thrust washers must be re-installed.
- 7) To separate final housing, item 100, from brake housing, item 700, first remove circlip, item 513, from the hub of the cable drum. Insert two heel bars between the drum flange and the final housing and carefully pry the cable drum out of ball bearing, item 103. Remove the internal retaining ring, item 104, to remove ball bearing, item 103, from inside the final housing. Remove and discard oil seal, item 105.

SERVICE INSTRUCTIONS CONTINUED

DISASSEMBLY OF FREESPOOL ASSEMBLY:

If a problem is occurring in the freespool assembly, follow instructions 1 and 2 from the section DISASSEMBLY OF FINAL DRIVE ASSEMBLY, then depending on whether you are working on a hydraulic or manually actuated model, proceed from here.

HYDRAULIC FREESPOOL (R7-X-135-1F):

- 1) Remove four hex capscrews, item 253, and lockwashers, item 255, from the end of the freespool assembly. Since the freespool spring, item 280, applies pressure against the inside of the freespool cover, it is recommended that the hex capscrews are unscrewed one turn at a time until the spring pressure has been released.
- 2) Discard o-ring, item 257, and remove the freespool spring.
- 3) Remove the freespool piston, item 264, along with the final sun gear, item 340, from the freespool cover and discard o-rings, item 265 and 277. Inspect the outside diameter of the piston and the internal diameter of the housing for any surface scratches due to particles in the hydraulic fluid (contamination). If there is any evidence of surface damage, polish with fine emery cloth.
- 4) Inspect nylon planet hub stopper, item 126, and replace if less than 1/8" thick. Remove and discard o-ring, item 123, from outside of freespool housing.
- 5) In order to separate the final sun gear, item 340, from the freespool piston, remove circlip, item 269. Inspect the two splines on the end of the final sun gear for wear and cracks, and replace if necessary.
- 6) To separate the ball bearing, item 291, from the final sun gear, remove circlip, item 269.

MANUAL FREESPOOL (R7-X-135-1M):

- 1) Remove hex head capscrew, item 297, and lockwasher, item 298, to allow removal of freespool handle, item 254, from nut drive, item 256.
- 2) Remove four hex head capscrews, item 253, and lockwashers, item 255, from seal carrier, item 252. For correct positioning of the seal carrier upon reassembly, make a chalk mark on the outside top flange of the seal carrier and the freespool housing, item 250. Pull the seal carrier out of the freespool housing and discard o-ring, item 257, and oil seal, item 299.
- 3) Remove index, item 272, detent spring, item 276, and spring seat, item 284. Check these parts for wear and replace if necessary.
- 4) Turn the nut drive, item 256, to disconnect from the follower, item 266. Inspect the three spring pins, item 278, and replace if damaged or worn.
- 5) Remove circlip, item 288, and pull the final sun gear, item 340, together with the follower and ball bearing, item 291, out of the freespool housing.
- 6) Remove circlip, item 295, from the inside of the follower and pull the ball bearing, together with the final sun gear, out of the follower.
- 7) To separate the ball bearing, item 291, from the final sun gear, remove circlip, item 269.

The PULLMASTER Model R7 with freespool has now been completely disassembled.

REASSEMBLY:

Reassemble the winch following reverse procedure of disassembly. All parts should be thoroughly cleaned and only new, well greased o-rings and oil seals should be used.

IMPORTANT:

Before operation of the winch, refill lubricating oil (SAE 90) through the oil level hole in the end cover, and through the oil filler hole in the cable drum. The proper quantity is indicated on the winch SPECIFICATION sheet. To ensure proper reassembly, run the winch in both directions without load, prior to regular operation.

RECOMMENDED MAINTENANCE

It is recommended that the lubrication oil in the final drive housing and the drum interior is replaced after the initial 50 hours of operation. In order to maintain your PULLMASTER Model R7 planetary winch in peak operating condition at all times and over a long period, it is recommended that the following preventative maintenance procedure is carried out at least once a year or after 500 hours of actual operation, whichever occurs first:

- 1) Disconnect all hydraulic hoses and remove the winch from its mounting.
- 2) Disassemble the winch in accordance with the instructions given.
- 3) Discard and replace all O-rings and oil seals.
- 4) Inspect all parts for wear and replace if necessary.
- 5) Clean all parts with solvent before reassembly.
- 6) Reassemble the winch and re-fill lubricating oil (SAE 90) through the oil filler hole in the freespool housing and through the oil filler hole in the cable drum.

Note:

Although the wire rope is not part of the winch, a regular inspection will help to prevent potential accidents.

WHEN ORDERING REPAIR PARTS FOR THE PULLMASTER MODEL R7 PLANETARY WINCH, ALWAYS QUOTE THE SERIAL NUMBER OF THE UNIT.

MODEL NO. _____

SERIAL NO. _____

PULLMASTER WINCH CORPORATION reserves the right to change specifications and the design of PULLMASTER planetary winches at any time without prior notice and without incurring any obligations.

PARTS REFERENCE - FINAL DRIVE (R7-M)

ITEM NO.	QTY.	PART NO.	DESCRIPTION
100	1	22360	FINAL HOUSING
103	1	25150	BALL BEARING 110 X 170 X 28 #6022
104	1	20664	BEARING RETAINER #6022
105	1	26049	OIL SEAL 4.750 X 5.500 X .375
121	2	25032	PIPE PLUG 1/2 - 14 NPT
123	1	25484	O-RING -276 11"ID 1/8" CS
124	1	20663	COVER RETAINER
126	1	20662	PLANET HUB STOPPER
130	1	20458	BREATHER RELIEF ASSEMBLY
250	1	22248	FREESPOOL HOUSING
252	1	20966	SEAL CARRIER
253	4	25017	CAPSCREW - HEX HEAD 3/8 - 16NC X 1.0
254	1	20486	FREESPOOL HANDLE
255	4	25037	LOCKWASHER 3/8"
256	1	20477	FREESPOOL NUT DRIVE
257	1	25016	O-RING - 042 3-1/4"ID 1/16"CS
259	1	25379	SLOTTED SPRING PIN 5/32" X 1" L
266	1	20476	FREESPOOL FOLLOWER
268	1	25387	SLOTTED SPRING PIN 1/8"DIA X 3/8" L
269	1	25175	CIRCLIP ANDERTON # N1400 - 0078
272	2	20968	INDEX
276	2	20488	DETENT SPRING
278	3	25383	SLOTTED SPRING PIN 5/32 DIA 5/8"L
284	2	21075	SPRING SEAT
288	1	25378	CIRCLIP ANDERTON #N1300-0231
291	1	25172	BALL BEARING 020 X 042 X 12 #6004
295	2	25179	CIRCLIP ANDERTON # N1300 - 0165
297	1	25171	CAPSCREW - HEX HEAD 5/16 - 18NC x 7/8"L
298	1	25025	LOCKWASHER 5/16"
299	1	26009	OIL SEAL DAEMAR 175225312 1.750 X 2.250 X .31
300	1	20624	PLANET HUB
310	3	20659	PLANET PIN
311	3	25482	CIRCLIP ANDERTON # N1400 - 0018
313	3	25490	CIRCLIP ANDERTON # N1400 - 0125
320	3	22246	PLANET GEAR
321	6	25483	THRUST WASHER INA # AS 3047
323	60	25308	LOOSE ROLLER 7/32 DIA. X 1.50
340	1	22247	SUN GEAR
450	1	20653	PLANET HUB
453	1	20665	PLANET HUB STOPPER
460	3	20658	PLANET PIN
461	3	25060	CIRCLIP ANDERTON #N1800-0062
463	3	25119	CIRCLIP ANDERTON #N1400-0062
470	3	20657	PLANET GEAR
471	6	25486	THRUST WASHER TORRINGTON #FTA 1730
473	48	25270	LOOSE ROLLER 5/32 X 1.25 TOR. #E151-Q
500	1	22361	CABLE DRUM
502	1	20171	CABLE ANCHOR
503	1	25085	PIPE PLUG 3/8 - 18 NPT
513	1	25489	CIRCLIP ANDERTON # N1400 - 0425
553	16	25328	LOCKWASHER 7/16"
555	16	25265	CAPSCREW - HEX HEAD 7/16" - 14NC X 1.25
556	2	22374	TIE BAR

REFER TO PAGE 26 FOR WINCH SEAL KIT AND PAGE 28 FOR ASSEMBLY DRAWING.

FINAL DRIVE GROUP

G1080-C

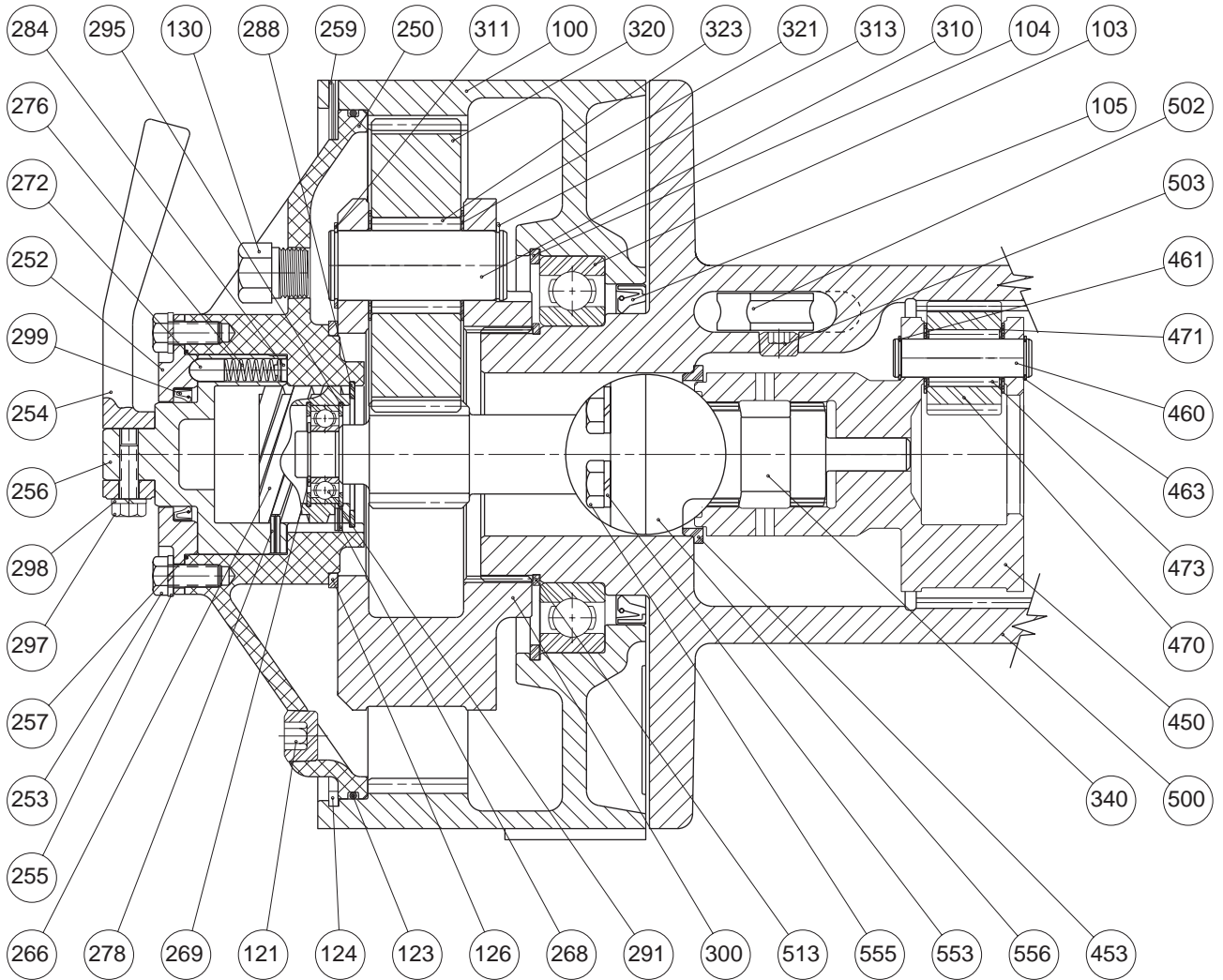

Groups drawings may reference more parts than are actually present in a specific assembly. Parts that are referenced on the drawing but are not on the PARTS REFERENCE list should be ignored.

PARTS REFERENCE - FINAL DRIVE (R7-F)

ITEM NO.	QTY.	PART NO.	DESCRIPTION
100	1	22360	FINAL HOUSING
103	1	25150	BALL BEARING 110 X 170 X 28 #6022
104	1	20664	BEARING RETAINER #6022
105	1	26049	OIL SEAL 4.750 X 5.500 X .375
121	2	25032	PIPE PLUG 1/2 - 14 NPT
123	1	25484	O-RING -276 11"ID 1/8" CS
124	1	20663	COVER RETAINER
126	1	20662	PLANET HUB STOPPER
130	1	20458	BREATHER RELIEF ASSEMBLY
250	1	22254	FREESPOOL HOUSING
251	1	25374	PLASTIC CAPPLUG 1/8 NPT
252	1	22279	FREESPOOL COVER
253	4	25264	CAPSCREW - HEX HEAD 3/8 - 16NC X 1.0
255	4	25037	LOCKWASHER 3/8"
257	1	25016	O-RING - 042 3-1/4"ID 1/16"CS
259	1	25379	SLOTTED SPRING PIN 5/32" X 1" L
264	1	20894	FREESPOOL PISTON
265	1	25628	O-RING -235 3-1/8"ID 1/8"CS
269	1	25175	CIRCLIP ANDERTON # N1400 - 0078
277	1	25477	O-RING -236 3-1/4"ID 1/8"CS
280	1	20159	FREESPOOL SPRING
291	1	25172	BALL BEARING 020 X 042 X 12 #6004
295	1	25179	CIRCLIP ANDERTON # N1300 - 0165
300	1	20624	PLANET HUB
310	3	20659	PLANET PIN
311	3	25482	CIRCLIP ANDERTON # N1400 - 0018
313	3	25490	CIRCLIP ANDERTON # N1400 - 0125
320	3	22246	PLANET GEAR
321	6	25483	THRUST WASHER INA # AS 3047
323	60	25308	LOOSE ROLLER 7/32 DIA. X 1.50
340	1	22247	SUNGEAR
450	1	20653	PLANET HUB
453	1	20665	PLANET HUB STOPPER
460	3	20658	PLANET PIN
461	3	25060	CIRCLIP ANDERTON #N1800-0062
463	3	25119	CIRCLIP ANDERTON #N1400-0062
470	3	20657	PLANET GEAR
471	6	25486	THRUST WASHER TORRINGTON #FTA 1730
473	48	25270	LOOSE ROLLER 5/32 X 1.25 TOR. #E151-Q
500	1	22361	CABLE DRUM
502	1	20085	CABLE ANCHOR
503	1	20171	PIPE PLUG 3/8 - 18 NPT
513	1	25489	CIRCLIP ANDERTON # N1400 - 0425
553	16	25328	LOCKWASHER 7/16"
555	16	25265	CAPSCREW - HEX HEAD 7/16" - 14NC X 1.25
556	2	22374	TIE BAR

REFER TO PAGE 26 FOR WINCH SEAL KIT AND PAGE 29 FOR ASSEMBLY DRAWING.

FINAL DRIVE GROUP

G1081-C

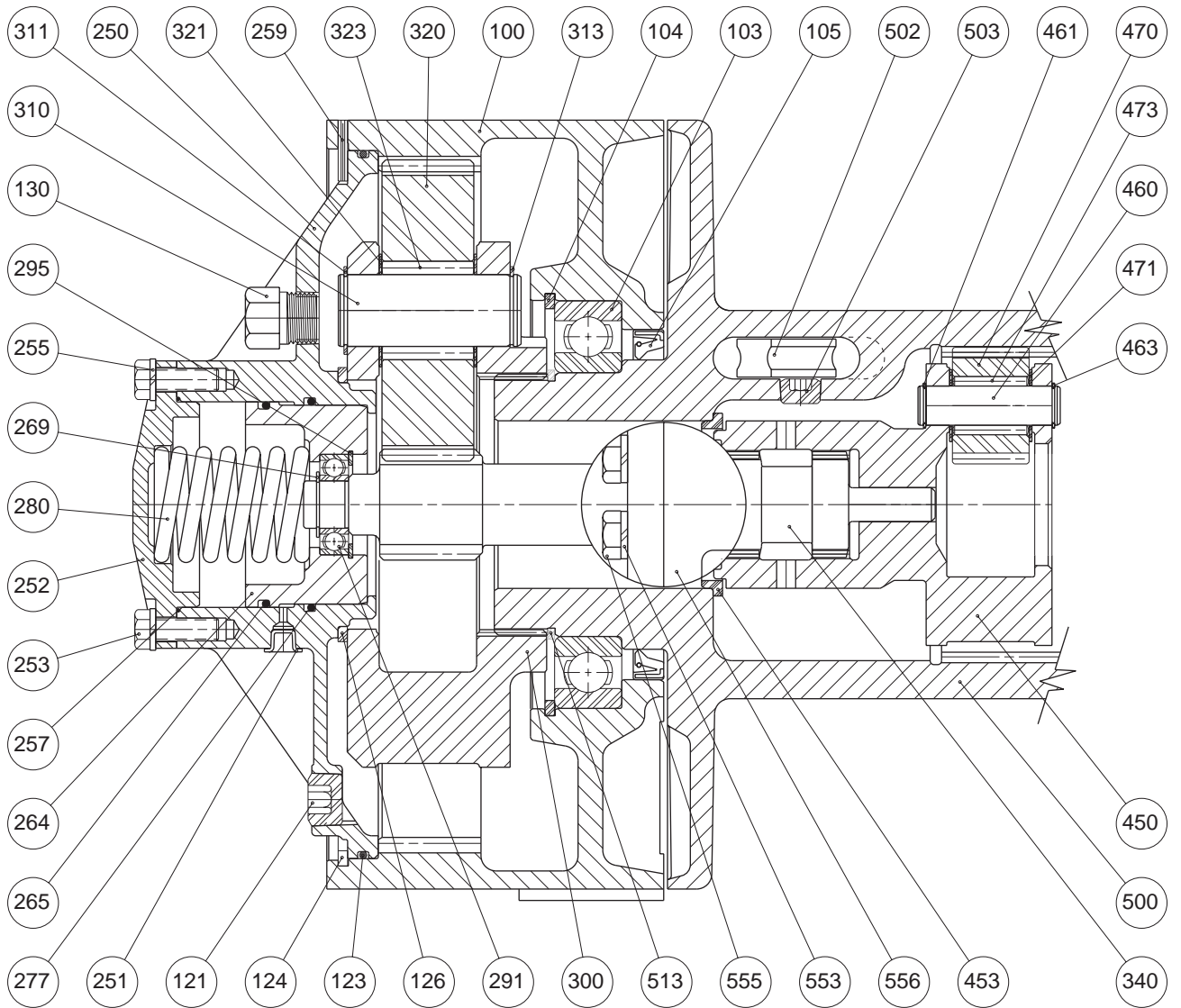

Groups drawings may reference more parts than are actually present in a specific assembly. Parts that are referenced on the drawing but are not on the PARTS REFERENCE should be ignored.

PARTS REFERENCE - BRAKE GROUP

ITEM NO.	QTY.	PART NO.	DESCRIPTION
400	1	20660	PLANET HUB
402	1	20372	SPACER
410	3	20080	PLANET PIN
411	3	25060	CIRCLIP ANDERTON # N1800 - 0062
413	3	25060	CIRCLIP ANDERTON # N1800 - 0062
420	3	20101	PLANET GEAR
421	6	25064	THRUST WASHER TORRINGTON # TRA 1018
423	3	25269	NEEDLE BEARING TORRINGTON # BH1016
440	1	20670	SUNGEAR
490	1	20669	SUNGEAR
491	1	25377	CIRCLIP ANDERTON # A1000 - 0162
494	1	20450	SUNGEAR STOPPER
509	1	25480	CYLINDRICAL ROLLER BRG. SKF #N217 (85X150X28)
515	1	25148	OIL SEAL 5.500 X 6.250 X .500
700	1	*	BRAKE HOUSING
704	1	20372	SPACER
707	1	25275	O-RING -048 4-3/4"ID 1/16"CS
708	1	*	CHECK VALVE SUB-ASSY
709	1	*	PLASTIC CAPPLUG 1/8 NPT
710	1	20714	BACK-UP WASHER FOR OIL SEAL #25278
711	1	25278	OIL SEAL GACO DPSM 30407
712	1	20107	BRAKE SPACER
713	7	25024	DIVIDER PLATE HI-LINE #19205
716	6	20034	FRICITION PLATE
719	1	25539	CIRCLIP ANDERTON # N1500 - X118
720	1	20640	BRAKE HUB
722	1	20183	SPRAG CLUTCH ALIGNER
723	1	25187	SPRAG CLUTCH BORG WARNER #X138769
724	1	20183	SPRAG CLUTCH ALIGNER
727	1	25492	CIRCLIP ANDERTON # N1400 - 0106
730	1	22214	MOTOR DRIVE SHAFT
731	1	25500	CIRCLIP ANDERTON # N1800 - 0093
737	2	25483	THRUST WASHER INA #AS 3047
739	1	25537	THRUST WASHER INA #AXK 3047
750	1	20727	PISTON
751	1	25528	O-RING -245 4-3/8"ID 1/8"CS
752	6	20340	BRAKE SPRING
753	1	25261	O-RING -246 4-1/2"ID 1/8"CS
754	1	20732	ORIFICE PLUG
757	1	25040	PIPE PLUG 1/8 - 27 NPT
759	1	*	STEEL BALL
800	1	*	MOTOR ADAPTOR
811	1	25016	O-RING - 042 3-1/4" ID 1/16"CS
815	2	25264	CAPSCREW - HEX HEAD 3/8 - 16NC X 1.00
817	2	25037	LOCKWASHER 3/8"
821	4	25264	CAPSCREW - HEX HEAD 3/8 - 16NC X 1.00
823	4	25037	LOCKWASHER 3/8"
830	1	20519	CONNECTING TUBE
831	2	25018	O-RING -010 1/4" ID 1/16"CS
840	1	20870	SAFETY VALVE
850	1	*	MOTOR -135 COMM. M315 - 1.5 GS
		26035	WINCH SEAL KIT, CONSISTS OF: ITEMS: 105, 123, 257, 265, 277, 299, 515, 707, 710, 711, 751, 753, 811, AND 831
			* These part numbers vary according to brake code. Refer to Appendix A.

REFER TO PAGES 28 & 29 FOR ASSEMBLY DRAWINGS.

BRAKE GROUP

G-1077-E

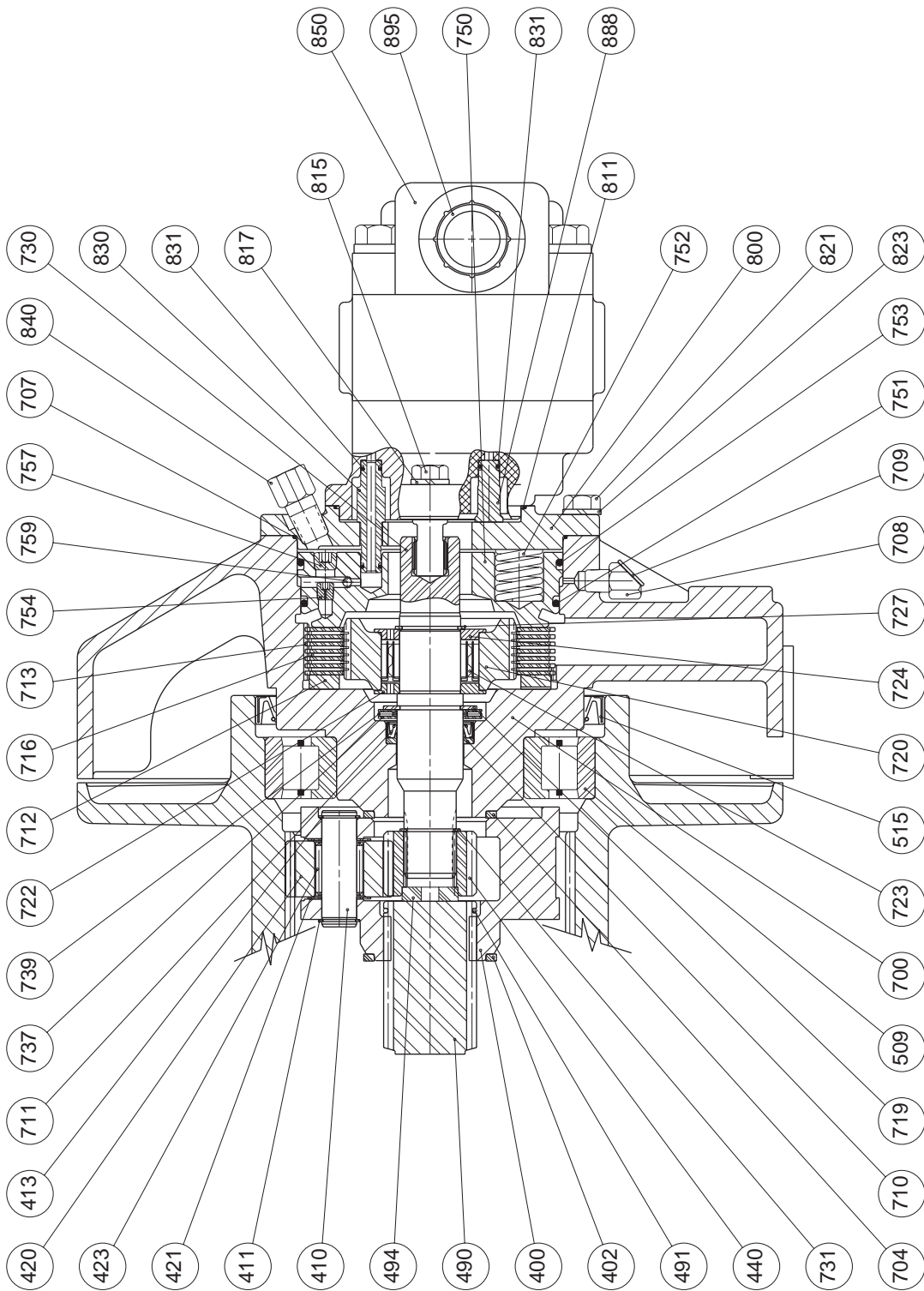

GROUP DRAWINGS MAY REFERENCE MORE PARTS THAN ARE ACTUALLY PRESENT IN A SPECIFIC ASSEMBLY. PARTS THAT ARE REFERENCED ON THE DRAWING BUT ARE NOT ON THE PARTS REFERENCE SHOULD BE IGNORED.

INSTALLATION DIMENSIONS (R7-M)

I1030-C

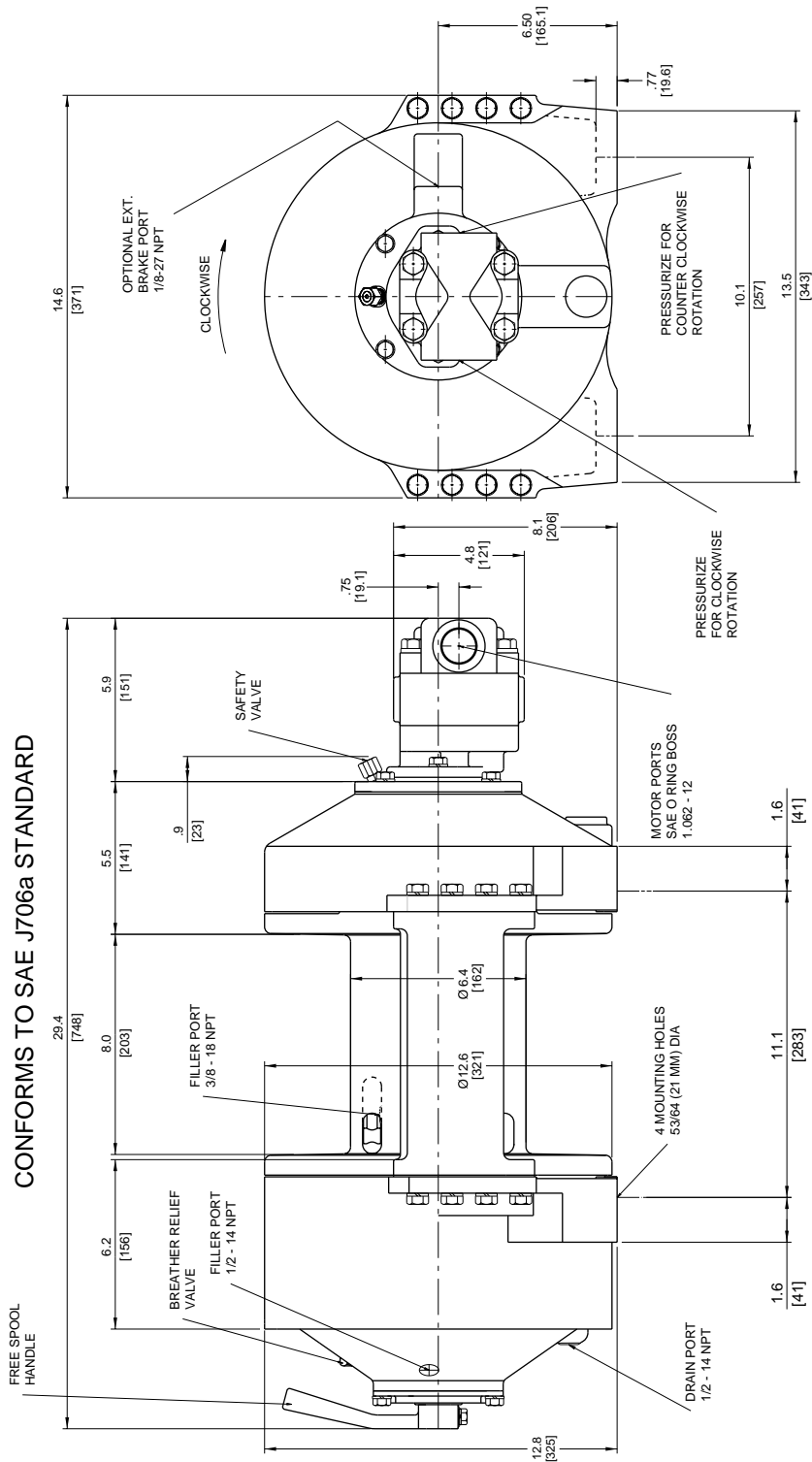

FOR SAFETY:
A MINIMUM OF 5 WRAPS OF WIRE ROPE MUST BE MAINTAINED AT ALL TIMES

CABLE ANCHOR SUITABLE FOR 1/2 TO 5/8 DIA. CABLE

INSTALLATION DIMENSIONS (R7-F)

I1031-D

CONFORMS TO SAE J706a STANDARD

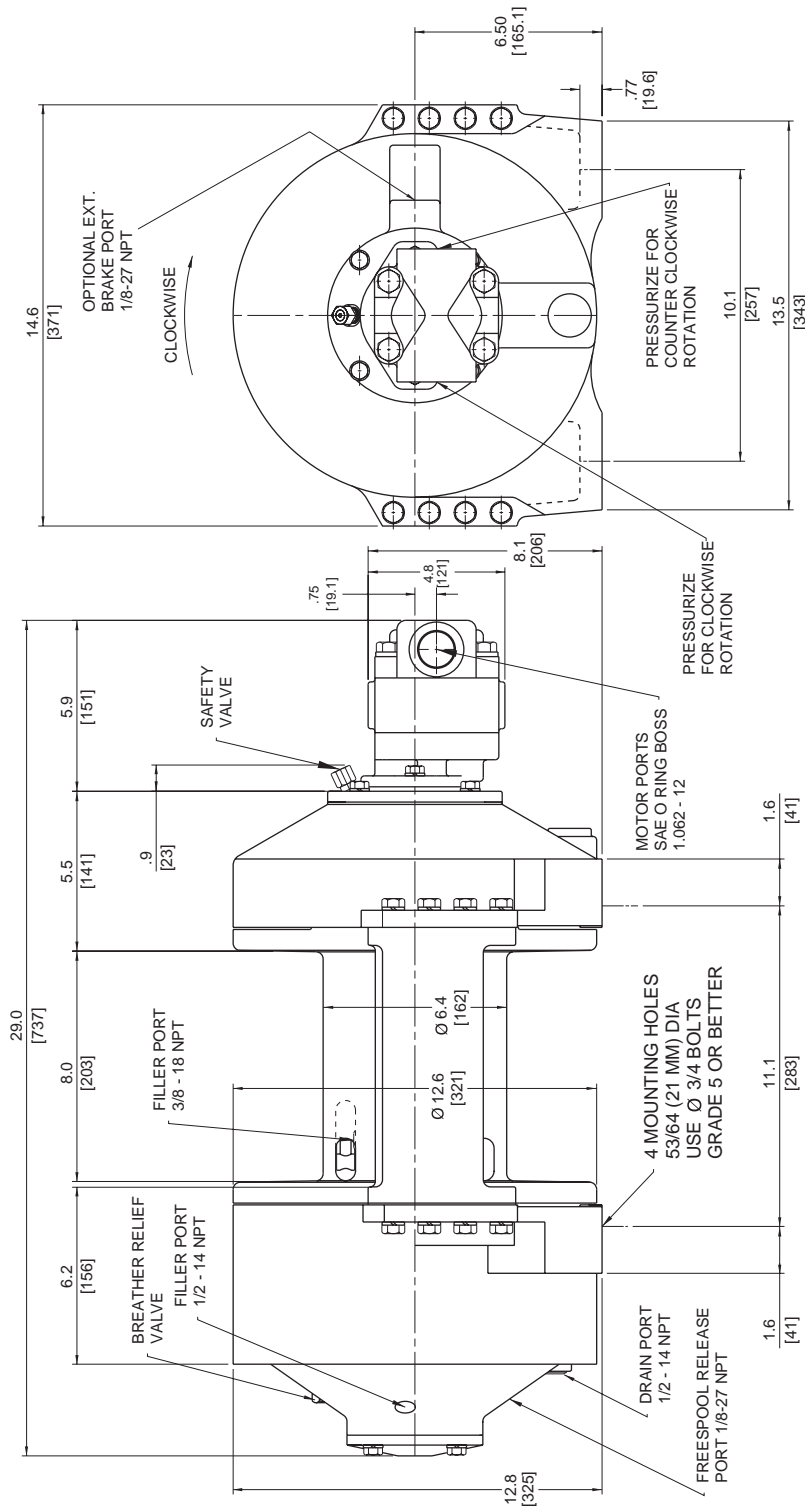

FOR SAFETY: A MINIMUM OF 5 WRAPS OF WIRE ROPE MUST BE MAINTAINED AT ALL TIMES

CABLE ANCHOR SUITABLE FOR 1/2 TO 5/8 DIA. CABLE

ASSEMBLY DRAWING (R7-M)

G1077-E & G1080-C

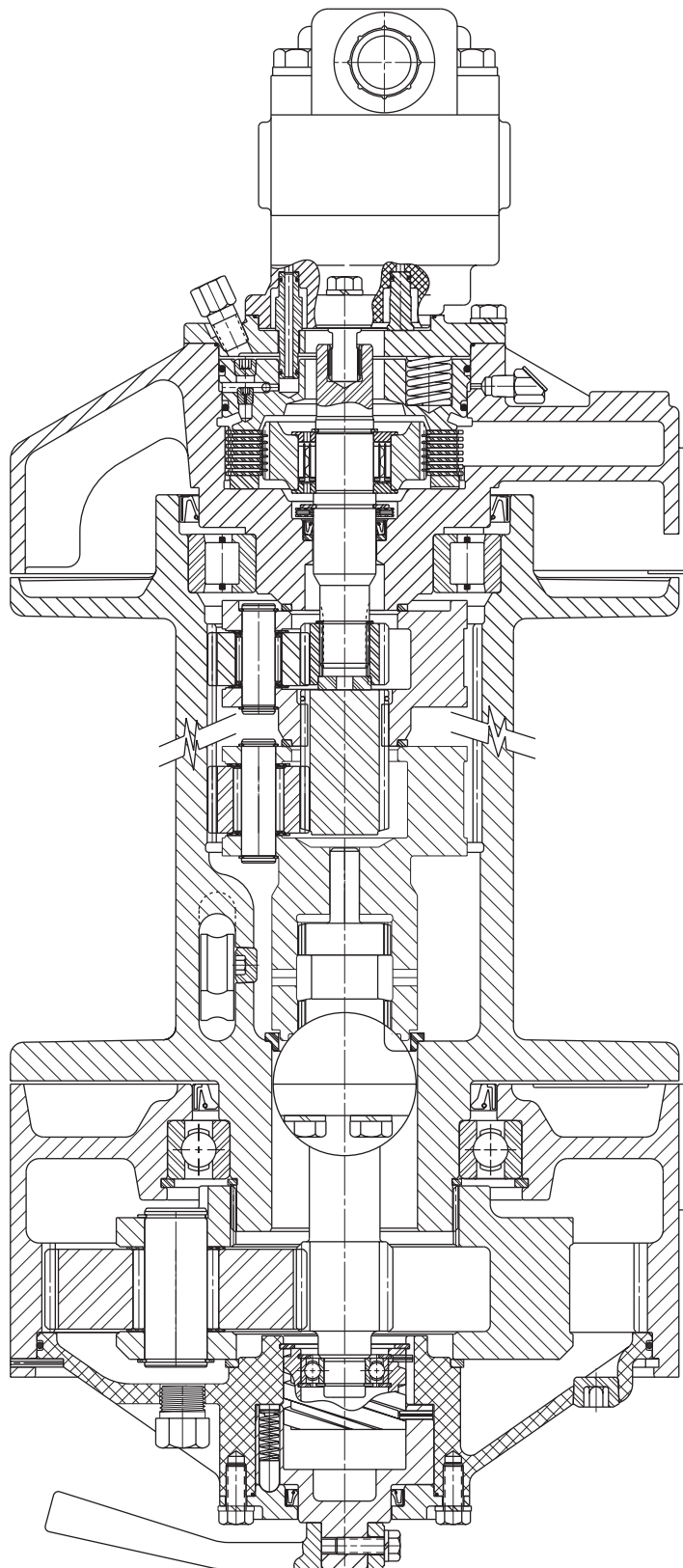

ASSEMBLY DRAWING (R7-F)

G1077-E & G1081-C

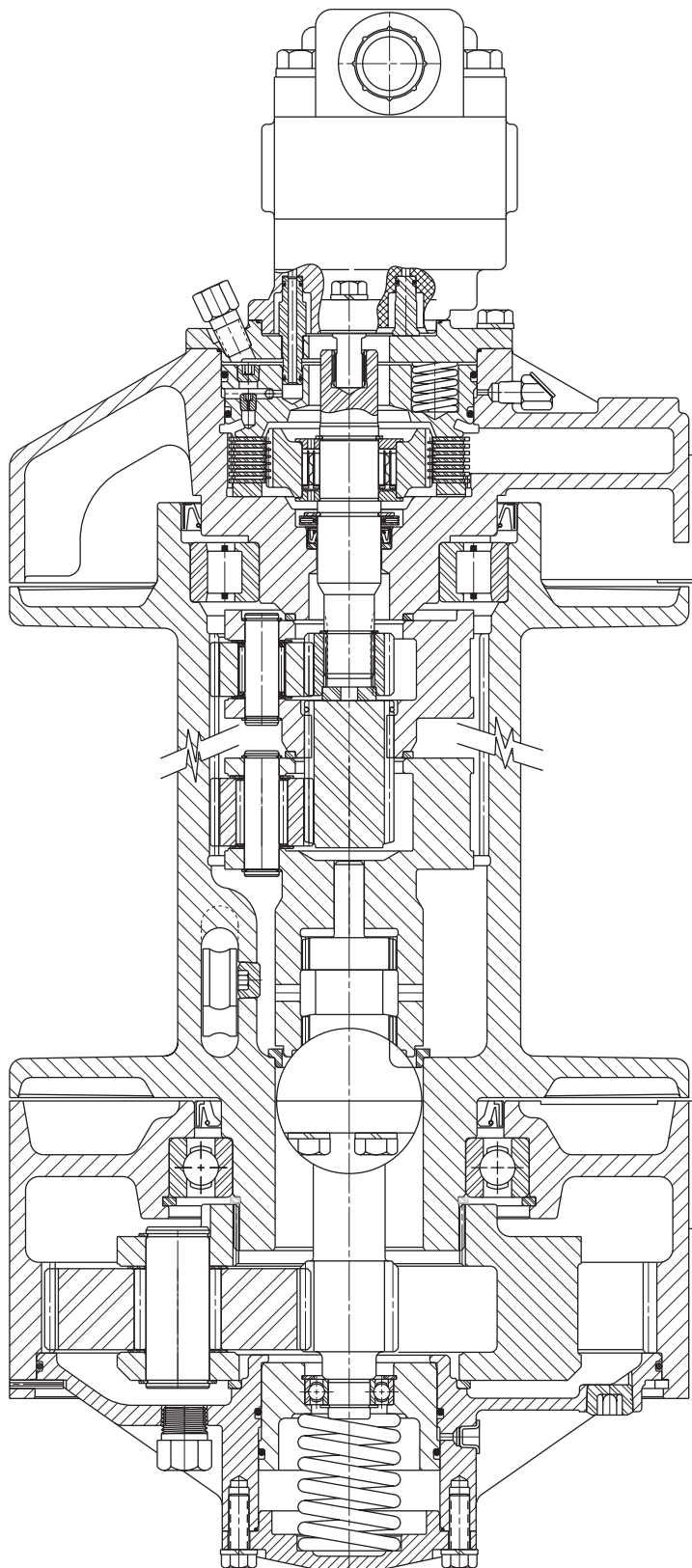

APPENDIX A

ITEM NO.	PART DESCRIPTION	PART NUMBERS			
		BRAKE CODE			
		- 12	- 13	- 14	- 15
700	BRAKE HOUSING	22213	22372	22372	22213
708	CHECK VALVE	N/A	21530	21530	N/A
709	PLASTIC CAPLUG	N/A	25374	25374	N/A
750	BRAKE PISTON	20727	20735	20735	20727
759	STEEL BALL	N/A	25533	25533	N/A
800	MOTOR ADAPTER	21079	21079	20716	20716
950	MOTOR	22255	22255	22331	22331

BOLT TORQUE CHART

BOLT DIAMETER Inches	TORQUE lb-ft	TORQUE Nm
1/4	9	12
5/16	18	24
3/8	32	43
7/16	50	68
1/2	75	102
9/16	110	149
5/8	150	203
3/4	265	359
7/8	420	569
1	640	868
1 1/8	800	1085
1 1/4	1000	1356
1 3/8	1200	1627
1 1/2	1500	2034

NOTE: Unless otherwise specified, torque bolts per above chart.

